

INTRODUCTION TO PRODUCT

The EZ Batch II micro-processor is a simple no frills batching unit designed as a low cost measurement alternative, built with high quality components. With an installed base of over a thousand units, assuring your satisfaction with it's proven performance.

The micro-processor will accept most every flow meter manufacturers pulsed outputs. EZ Batch II accepts NPN Sinking, Contact Closures, Passive, Open Collectors, with an operating range of 6 to 30 VDC.

EZ BATCH II



INSTALLATION GUIDELINES

Locate the EZ Batch II in the best suited area for operator accessibility and the best operating environment possible.

Do not mount EZ Batch II in a classified or hazardous area, it is intended for general purpose use in safe areas only.

If mounting in areas high in humidity we suggest that EZ Batch II remains *powered* at all times, heat produced by the components should help the controls remain dry with less corrosion.

Avoid mounting EZ Batch II in direct sunlight, the L.E.D. display is not viewable in sunlight and the suns UV rays will deteriorate the keypad and bezel.

Provide the EZ Batch II clean 110/60 VAC power, we suggest using a line filter and surge suppression. Voltage spikes or surges will corrupt the EEPROM.

The standard EZ Batch II is delivered in a fiberglass enclosure. Observe all local electrical codes for grounding of non-metallic enclosure s.

All conduit entrances in the enclosure should be in the bottom or sides only. When drilling the enclosure use care, prevent damage to components.

Caution, relay rating is 5 Amps maximum @ 110/60 VAC, you may use the courtesy 110/60 VAC L1 terminal 6 to provide voltage to the common of relay 1 and relay 2, can provide equipment i.e. valves and pumps the power necessary for control.

OPERATION AND INSTALLATION MANUAL

OPERATION SEQUENCE

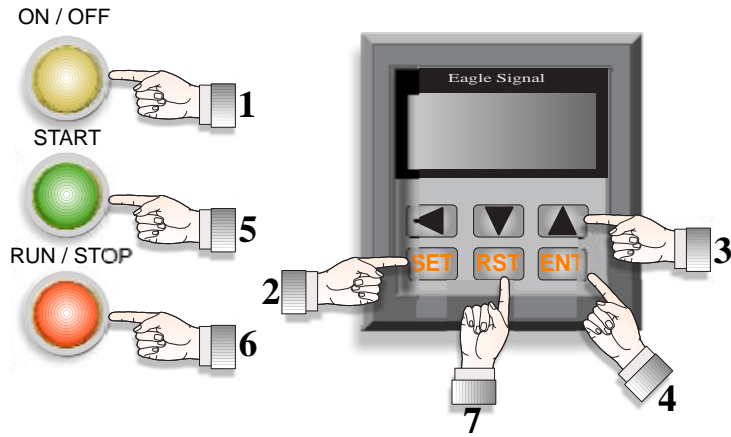

Step 1 Push the **ON / OFF** button, this will illuminate the button and provide power to the EZ Batch II controller.

Step 2 Press the **SET** key, the far right least significant digit on the L.E.D. display is flashing. Only the flashing digit can be changed.

Step 3 Use the **▲ UP**, **▼ DOWN** and **◀ OVER Arrow** keys to change the digits and select the desired preset amount.

Step 4 Press the **ENT** key, the preset is downloaded into memory. The preset will remain the same until a new preset is entered.

Step 5 Press the **START** button this will illuminate the button and also send a momentary signal to the EZ Batch II controller energizing the relay outputs opening a valve and or starting a pump. The controller will measure the liquid passing through the flow sensor and de-energize at batch completion.

Step 6 Press the **RUN / STOP** button, this will illuminate the button and disconnect all power to the relays thus stopping the process. Press the **RUN / STOP** button again and resume running the batch until completion.

Step 7 Press the **RST** key and release. This will **RESET** and **CLEAR** all digits on the L.E.D. display. Use this function when a batch will not be completed. Unless the preset has completed, a new batch cannot be started until the controller has been reset.

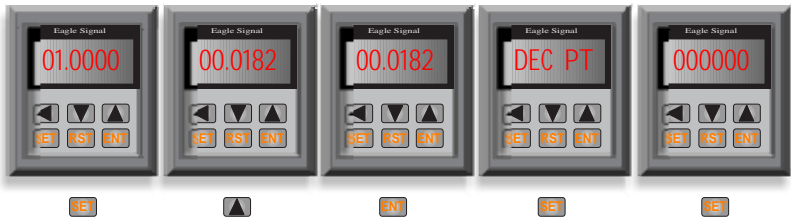

Press **SET** key once, display changes to show value.

Use arrow keys to enter desired scale factor number.

Press **ENT** key to enter scale factor into memory.

Press **SET** key once, display changes to *Dec Pt.*

Press **SET** key once, display changes to show place.

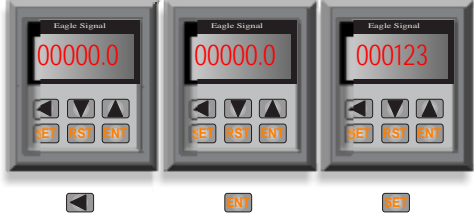

Use the arrow over key to select a decimal point location.

Press **ENT** key to enter a decimal point into memory.

Press **SET** key once, display changes to preset mode.

The **SET** key is used to access the programming mode.

Pushing the **SET** key prompts the next display to appear in the order listed in the programming menu.

If programming changes are not needed use the **SET** key to skip to the next parameter.

OTHER FEATURES

Keypad Lock Function
To **LOCK**, press and hold **ENT** key for 15 to 20 seconds. This will lock the keypad, *no setpoint changes will be accepted.*

To **UNLOCK**, press and hold **ENT** key for 15-20 seconds. This will unlock the keypad, *setpoint changes will be accepted.*



Batch Progress Indication

Start of batch the left L.E.D. indicates the batch is in progress and CR-1 closes.

At setpoint 2 when both L.E.D. indicators are on. This indicates prewarn is reached. CR-1 opens.

End of batch the right L.E.D. indicated the valve is closed and the pump is off. CR-1 is open and CR-2 is closed.

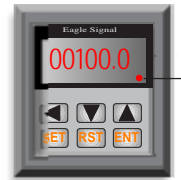
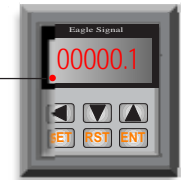

Under-Run

At the end of the batch if both L.E.D. indicators are on. This indicates an *Under-Run*. The batch did not count out completely, the valve closed too soon. Press **RST** to reset the controller. Set point 2 prewarn should be decreased in the amount of the *Under-Run*.

Over-Run

At the end of the batch if the right L.E.D. indicator is on and the count is more than the pre-set. This is an indication of an *Over-Run*. The valve closed too late. Setpoint 2 prewarn should be increased in the amount of the *Over-Run*.

PROGRAMMING MENU SEQUENCE

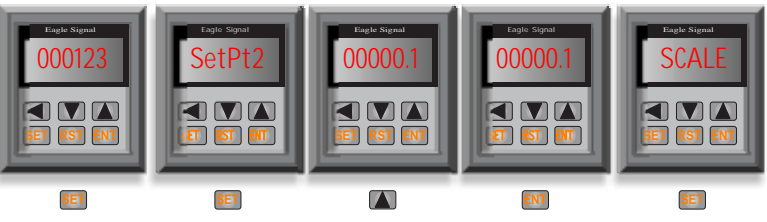

Hold in **SET** key for 15-20 seconds. Remove when display changes to *Set Pt 2*

Press **SET** key once, display changes to show value.

Use Arrow keys to enter setpoint 2 value for prewarn.

Press **ENT** key to enter setpoint 2 into memory.

Press **SET** key once, display changes to *Scale*.

CALIBRATION

Adjusting Calibration

Two calibration modes are available on the EZ Batch II controller multiplier and divider modes. The multiplier mode is the standard configuration mode for EZ Batch II controllers.

Multiplier Calibration Formula

$$\text{Amount Delivered} \div \text{Amount on Display} \times \text{Existing Scale Factor}$$

Example a flow meter was tested running water into a drum on a scale, the display showed 400.0 lbs. of water was delivered, the scale showed 402.5 lbs.

$$\text{Amount delivered } 402.5 \div 400 = 1.00625$$

The answer 1.00625 is the amount of error the test indicated and is now the multiplier factor of the existing scale factor in the EZ Batch II controller.

To Adjust Calibration

Access the Scale factor numeric display using the Programming Menu. The value displayed in the Scale factor numeric display is the existing Scale factor.

$$\text{Take the (existing Scale factor } 00.1810) \times (\text{amount of error } 1.00625) = (00.1821 \text{ New Scale factor)}$$

Using the arrow keys change the Scale factor numeric display to the new value.

Press the ENT key to enter the new value into memory, exit the Programming Menu.

Units of Measure Multiplier Mode

Most flow meters have a K factor which represents the number of pulses per gallon the meter outputs. the unit desired is divided by the K factor to establish the starting Scale factor.

Example using a 2" Turbine flow meter with Water producing 55.21 pulses per gallon

Volumetric Units	Whole Gallons	1	÷ 55.21 = 00.0181	starting Scale factor
	10 th Gallons	10	÷ 55.21 = 00.1811	" " " "
	100th Gallons	100	÷ 55.21 = 01.8112	" " " "
Mass Units	Whole Pounds	8.32	÷ 55.21 = 00.1506	" " " "
	10th Pounds	83.20	÷ 55.21 = 01.5069	" " " "

Divider Calibration Formula

$$\text{Amount on Display} \div \text{Amount Delivered} \times \text{Existing Scale Factor}$$

Use this formula and follow the same procedure described above. The divider mode is generally used with very high K factors where using a multiplier does not give enough resolution for proper calibration. The divider mode can easily be selected using the dip switches, see Dipswitch selection.

Units of Measure Divider Mode

The K factor is divided by the desired unit to establish the starting Scale factor.

EZ BATCH II WIRING

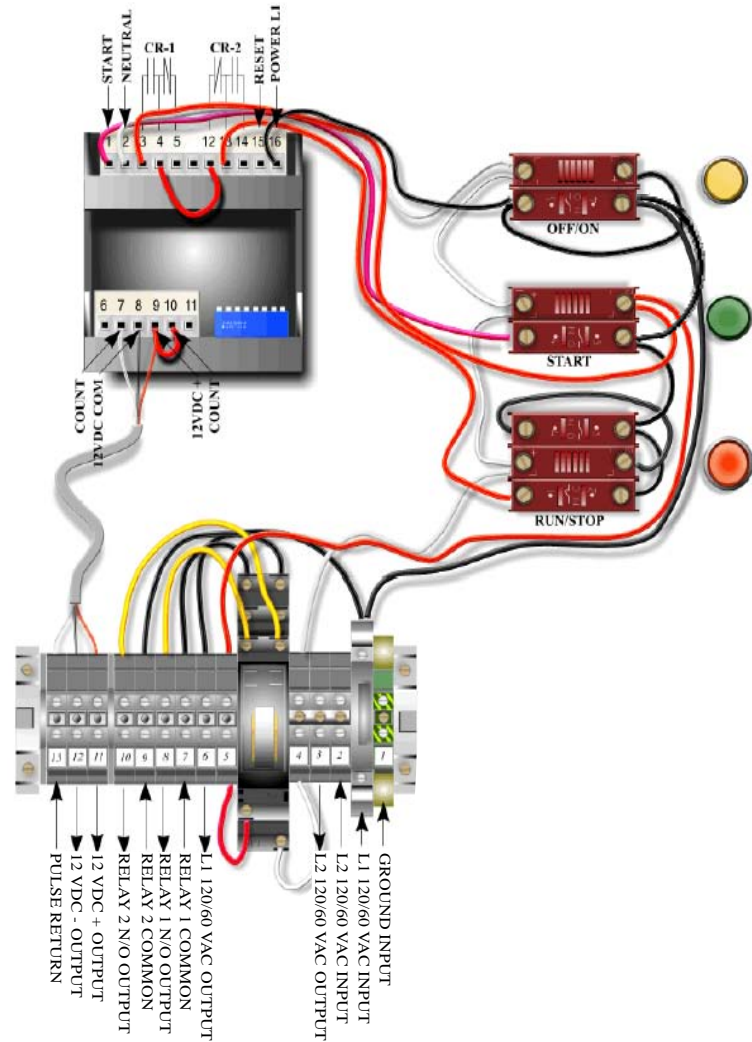

FIELD WIRING

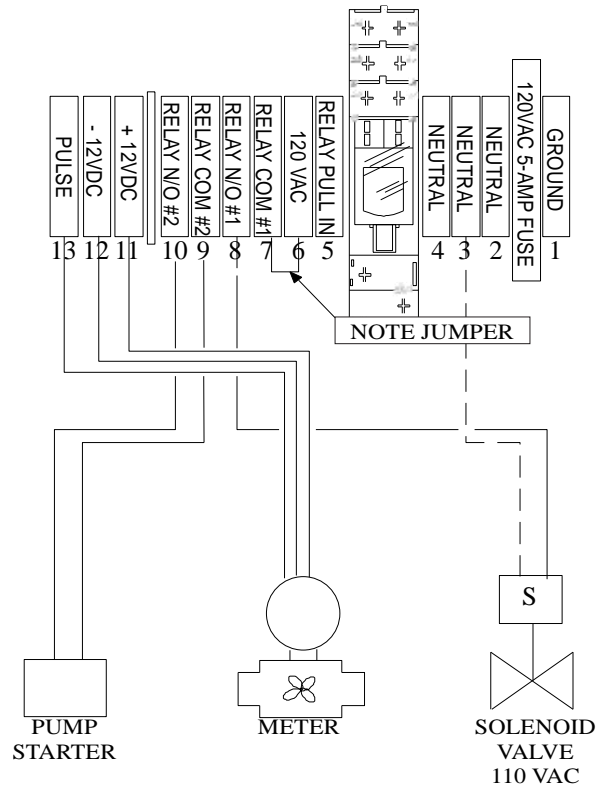

DIPSWITCH SELECTION

Standard Rocker Switch

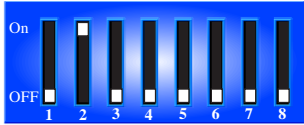

Configuration

DIP SWITCH SELECTION

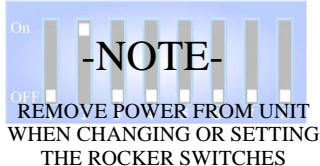

Any switch changes made while unit is powered **will not be recognized until the unit has been cycled OFF and then ON again.**



If switch changes have been made and power has been cycled, all previous set point data is deleted from memory. The display will show (-----) six hyphens

OPERATING MODE SET-UP

ROCKER SWITCH PROGRAMMING

Switch No.	Switch Position	Operating Mode	Change or Edit Switch
1	OFF	Output 1 Control	NO
2	ON	Output 1 Control	NO
3	OFF	Output 1 Control	NO
4	OFF	Output 2 Control	NO
5	OFF	Count Up	YES
5	ON	Count Down	YES
6	OFF	Multiply Scaler	YES
6	ON	Divide Scaler	YES
7	OFF	Non-Reset on Power Loss	NO
8	OFF	Momentary Start Input	NO

EZ BATCH II SPECIFICATIONS

Operating Voltage:

*120/60VAC, 18VA max
± 10%

Output Relay:

*DPDT 5Amp 10/240VAC

Count Input Voltage:

*10.5-28VDC

Count Speed:

*2.5 KHz max (npn)

Sensor Power Supply:

*+12VDC, 100mA max

Setting Accuracy:

*Count-100%, pulse output time
.001% of setting or 50ms. Which
ever is larger

Operating Temperature:

*32° to 122° F

Nema 4X Construction:

*Alternate action illuminated push
button controls

*Hoffman 8" x 10" x 7" fiberglass
enclosure

COMPLETE SYSTEMS

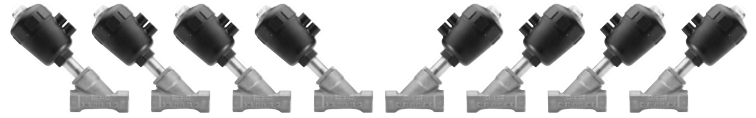

316 Stainless Steel Turbine Industrial Flow Meter Systems

Halliburton Industrial Flow Meters

These rugged meters have only one moving part, the rotor or propeller. As liquid flows through the meter, the rotor spins. A magnetic pickup is positioned outside the meter body to sense the edges of the rotor as it spins. A K-factor or pulses per unit is established for each turbine meter. Turbine meters can be very accurate, with proper installation and repeatable process variables, maintaining accuracy's of ±0.5% is possible. The turbine meters 316 SS body has no seals or seats to leak, and will outperform most any mechanical meter systems sold today.

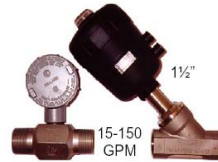

Burkert Industrial Angle Seat Valve

This heavy duty angle seat valve will outlast any ball valve actuator package sold. All 316SS construction, 2 spring loaded PTFE chevron seats isolate the liquid from the polyamide body. The 316 SS piston and PTFE valve seat provide positive and accurate shut off. Use of a 3/2 way air pilot valve provides on/off control for the normally closed air to open spring to close actuator.

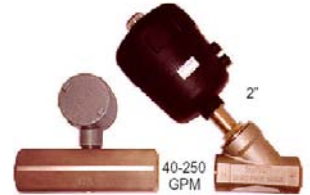

EZ Batch II Controller



EZ to use, simply enter the amount of product desired for your batch, press the start button and the rest is automatic.

Burkert 3/2 way Air Solenoid Valve

120/60 VAC UL, NEMA 4. (Standard)
Optional Voltages:
12VDC, 24VDC, 24VAC,
Class 1, Div.1, and 2
are Available on request



Meter System Selection

Base the turbine meter sizing on your products known or expected flow rate alone. Do not base your meter selection on your process line size. Recommended normal flow rates should at least double the minimum flow rate for the meter selected. For optimum performance, flow rates of 30 - 80% of maximum flow rate is desired.

1", 1-1/2", 2" 316 SS Turbine Meter Systems
Always in Stock is our policy

Complete System Includes:
Meter, Valve with Solenoid, Batch Controller
Standard System Pricing:

1"	\$1795.00	F.O.B. Redlands, Ca.
1-1/2"	\$2130.00	" " "
2"	\$2450.00	" " "

Pricing subject to change without notice

Positive Displacement and Mass Flow Meters Also Available



Meter Maintenance & Controls Inc.

1963 Essex Court Redlands, Ca. 92373
Ph (909) 307-2295 Fax (909) 307-2395

www.gommci.com

