

MC-II Flow Analyzer

User Manual

© 2003 NuFlo Technologies, Inc. All information contained in this publication is confidential and proprietary property of NuFlo Technologies, Inc. Any reproduction or use of these instructions, drawings, or photographs without the express written permission of an officer of NuFlo Technologies, Inc. is forbidden.

All Rights Reserved.
Printed in the United States of America.

Manual No. 100079666NZ
October 2003

TABLE OF CONTENTS

NOMENCLATURE I (EXTERNAL)	i
NOMENCLATURE II (INTERNAL)	ii
SPECIFICATIONS	1
GENERAL DESCRIPTION	2
INSTALLATION INSTRUCTIONS	2
A. General.....	2
B. Mounting on Flow Meter	2
C. Remote Mounting	3
OPERATION	3
MAINTENANCE	3
A. Battery Replacement	4
B. Circuit Assembly	4
C. Recalibration	4
CALIBRATION	4
A. Mode of Operation	4
1. Calibrate	4
2. Reset	4
3. Rate Multiplier.....	4
B. Divisor Calculation	5
1. Liquid Flow Meters	5
2. Gas Flow Meters	5
C. Divisor Entry	5
D. Rate Multiplier Calculation.....	6
E. Rate Multiplier Entry	6
F. MC-II Calibration Examples.....	8
SENSITIVITY ADJUSTMENT - FLOW METER SIGNAL.....	15
RECOMMENDED SPARE PARTS	16
OPTIONS	17
1. Totalizer and Flow Rate Units	17
2. Totalizer Reset	17
3. Remote Mounting	17
4. Two-Number Calibration.....	18
5. Calibration from Front Panel.....	18
6. Pulse Output.....	18
7. Pulse Output - Intrinsically Safe	20

TABLES

Table 1 – Maximum Size of Rate Multiplier Entry 7
Table 2 – Pulse Output Divide-By Selection 19

ILLUSTRATIONS

Figure 1 Dimensional Drawing - Direct Mount 23
Figure 2 Dimensional Drawing - Remote Mount 24
Figure 3 Wiring Diagram 25
Figure 4 Calibration Jumper Position 26
Figure 5 Pulse Output Circuit Assembly - Part No. 100005121 27
Figure 6 Pulse Output Circuit Assembly – Intrinsically Safe - 27
Part No. 100005163
Figure 7 Pulse Output Option: Wiring & Cord Installation 28
Figure 8 Pulse Output Installation (Dry Contact, Open Collector & Opto-
Isolated) Field Wiring Diagrams 29
Figure 9 Pulse Output - Installation - Intrinsically Safe (Dry Contact, Open
Collector & Opto-Isolated) Field Wiring Diagrams 30

APPENDIX - Lithium Battery Information

Lithium Battery Disposal A-1
Transportation A-2
Instructions for Packaging Lithium Batteries A-3
Instructions for Packaging MC-II Flow Analyzers A-7
Material Safety Data Sheet – MC-II Flow Analyzers A-10
Material Safety Data Sheet – MC-II Lithium Battery A-16

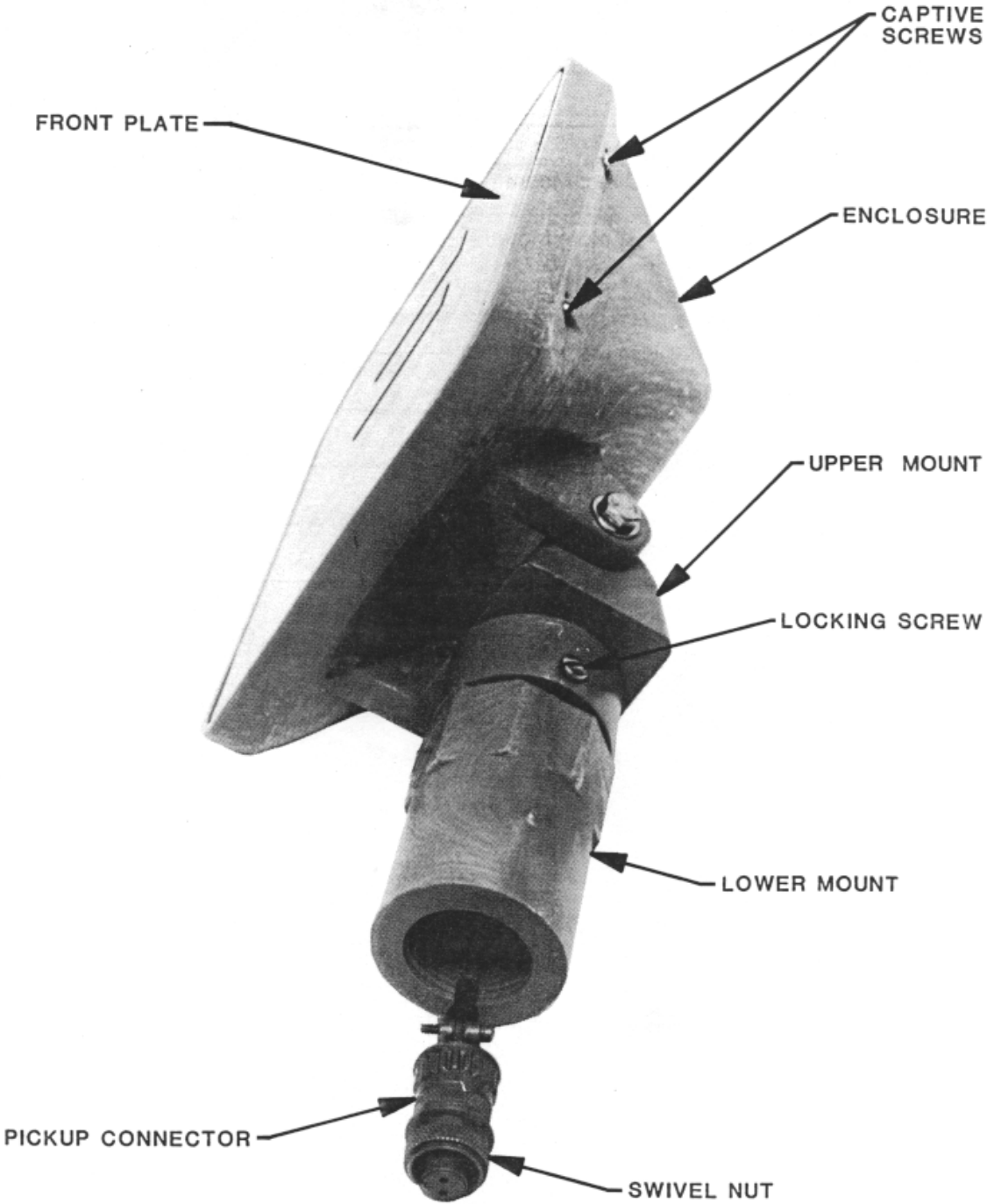

Nomenclature 1

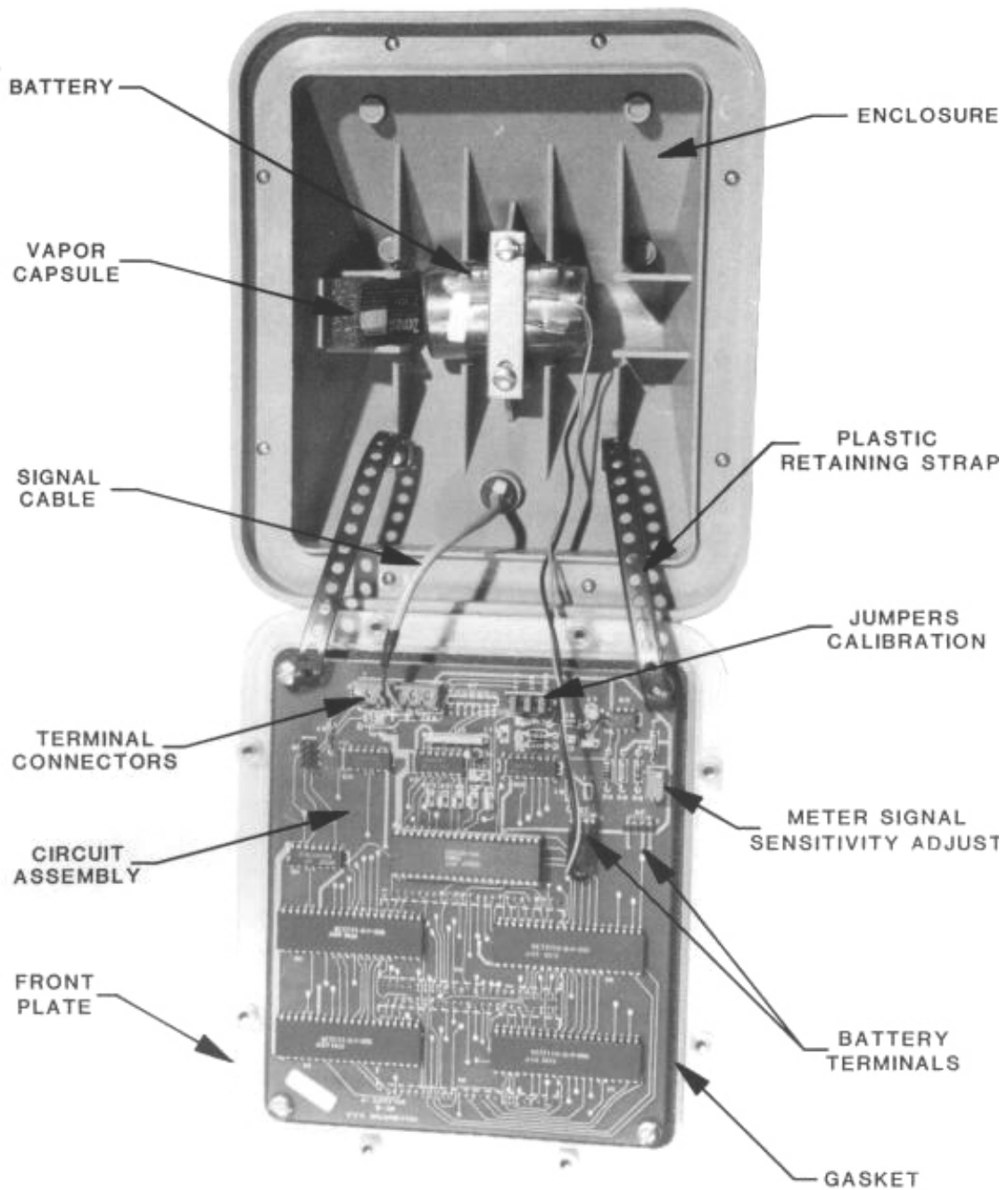

Nomenclature 2

Specifications – Standard Unit Without Options

Size:

7.3 in. wide x 8.3 in. high x 3.4 in. deep

Shipping Weight:

6 lb. including shipping container

Power supply:

One 3.6 volt lithium battery (supplied with instrument)

Battery life:

3 to 5 years typical

Temperature range:

-40 to +140 deg. F (-40 to +60 deg. C)

Totalizer:

Six digits, 0.5 in. character height, registering barrels (1/10, 1/100 available)
Divisor capabilities from 1 to 32,767
Maximum count rate is 35 Hz

Flow rate:

Six digits, registering barrels per day
Updates once per second

Accuracy:

±1 count (totalizer)

Input frequency:

0 to 2000 Hz

Input amplitude:

30 to 3000 mV peak to peak

Signal cable:

1 ft.

Mounting:

MC-II enclosure mounts directly on polyethylene weatherproof pickup adapter (provided) which threads onto turbine meter. Weatherproof pickup adapter designed to tilt and swivel to provide ease of reading display.

Compliances:

UL listed, CSA certified intrinsically safe in hazardous locations
Class I, Division 1, Groups A,B,C,D

General Description

The NuFlo Measurement Systems Model MC-II Flow Analyzer receives an electronic pulse train from a flow meter and provides a registration of totalized flow and an indication of flow rate by utilization of its microprocessor-based circuitry. The totalized flow and flow rate are displayed on two six-digit liquid crystal displays (LCD's). Both displays are properly labeled with respective units of measurement.

The low current draw of its CMOS circuitry enables the MC-II to run for three to five years on a single battery.

The MC-II has the advantage of being battery powered and enclosed in a non-corrosive weatherproof housing, an ideal combination for use in remote locations.

Installation Instructions

A. General

The Model MC-II Flow Analyzer was designed to be mounted either directly atop its companion flow meter or, with optional hardware, on vertical or horizontal 2" pipe. Either type mount should be free of vibration. Each MC-II is calibrated for operation with a particular flow meter at the factory, but it can be recalibrated for any compatible flow meter on site. Refer to Calibration Section of this manual if recalibration is needed. The serial numbers of companion flow meters and readouts may be determined from the shipping and/or packing information. The serial number for the MC-II is located on the back of the housing. The serial number also appears on the outside of the shipping carton. The serial number for the flow meter is stamped on the flow meter body and also appears on its shipping carton.

It is good practice to orient MC-II's such that the liquid crystal displays are not exposed to direct sunlight.

B. Mounting on Flow Meter

The MC-II is shipped completely assembled. After the flow meter has been installed in the flow line according to the instructions furnished with it, the pickup should be installed, also according to the flow meter instruction manual. If remote mounting option was ordered along with the instrument, refer to Options Section 3, page 17. It is advisable to grease the pickup threads before screwing them into the flow meter body to facilitate easy removal in the future. For the same reason, grease the pickup threads which mate with the connector. Plug the connector on the end of the MC-II signal cable into the pickup and turn the swivel nut until the connector is fully inserted into the pickup and the swivel nut is hand-tight. Loosen the locking screws which hold the base MC-II mount secure.

Position the MC-II on the flow meter, carefully pulling excess signal cable through the strain relief cord connector on the side of the upper mount (refer to Nomenclature I, page i and Figure 1, page 23). Thread the base of the mount onto the conduit adapter of the turbine meter and tighten two extra rounds after it is hand-tight. It is important that the upper mount and MC-II readout be kept from turning while the base is being tightened in order to prevent the signal cable from being damaged by twisting. Tighten the outside nut of the strain relief cord connector on the upper mount with a 15mm open-end wrench to prevent cord slippage. Adjust the MC-II readout for best viewing position and tighten the locking screws in the upper mount. The viewing angle may be adjusted by loosening the nut on the bolt which holds the MC-II readout on the upper mount, tilting to the desired angle and retightening.

C. Remote Mounting

The MC-II Flow Analyzer is designed to be installed directly atop the flow meter; but if the flow meter is in a line which has vibration or if the location of the meter makes it undesirable to mount the MC-II directly on the meter, remote mounting hardware is available to allow the MC-II to be mounted on a 2-inch pipe (refer to Options Section 3, page 17).

Operation

After proper installation and calibration, the MC-II is ready for operation. If the MC-II was not ordered with a companion flow meter and needs to be calibrated for the meter it is to be used with, see Calibration Section, page 4.

When fluid begins to pass through the flow meter, the MC-II displays should register total accumulated flow volume and instantaneous flow rate. The decimal points will appear in their proper position in the displays when the units are properly calibrated.

If the flow rate exceeds the capabilities of the display, an "E" will appear in the far left-hand digit of the rate display, followed by the lower five digits of the rate display. The total display will remain accurate as long as the 35 counts per second rate is not exceeded.

The divisor and rate multiplier which are set into the MC-II will be displayed on the total and rate displays respectively when the **View/Div** button is pressed (see Figure 1, page 23). This button must be pressed for a few seconds in order to obtain this display. The divisor display may have a decimal point appearing in the display. This decimal point does not reflect the position of a decimal point in the divisor, as the divisor is always a whole number. The appearance of a decimal point means that the total display has been calibrated to show parts of a volume, such as 1/10 gallons or 1/100 barrels. The decimal point is determined by the limitation on the maximum number that can be used for a divisor (maximum number for whole units is 32767, see Calibration Section, page 4). When the Totals divisor is viewed, the appearance of a decimal point and numbers in the top display is expressing two pieces of information at the same time. The first piece of information is the divisor entered in whole numbers. The second piece of information is the decimal point position which was determined during the calibration procedure. However, the decimal point appearing in the rate multiplier display is in the actual position occupied by a decimal point in the multiplier.

The accumulated flow total may be reset to zero by pressing the **Reset** button if the reset function is enabled. This button may have to be pressed for a few seconds in order to implement a reset.

Maintenance

To gain access to the internal portion of the MC-II, loosen the eight captive screws around the outer edge on the back of the enclosure. Once all of these screws are loose, the front plate of the MC-II should fold down, hinging on the plastic retaining straps at the bottom of the enclosure. It may be necessary to use a thin screwdriver blade to pry the front plate free, but do not use excessive force. The battery and circuit board should now be exposed for servicing.

CAUTION: Under normal operating conditions the MC-II poses no hazard when the enclosure is opened. The lithium battery which powers the MC-II is a sealed unit; but if one of these units leaks, there is a possibility of toxic fumes being present when the enclosure is opened. Select a well-ventilated area in which to open the enclosure and avoid breathing fumes that may be trapped inside. Care must be taken in handling and disposing of a damaged battery (see Appendix Section of this manual for additional safety information).

A. **Battery Replacement**

The battery used in the MC-II has a life expectancy of about three to five years. This battery has a very flat discharge curve, making it difficult to measure the battery voltage to determine the remaining battery life at any point in time. When the battery is replaced, the new battery must be connected to the unused battery terminals first before the old battery is disconnected, in order to prevent the loss of counts and calibration information. It is advisable to record the date of installation of replacement batteries to help ascertain when the next replacement may be required.

B. **Circuit Assembly**

The circuit assembly, Part No. 100005109, contains all of the electronic components. To remove this circuit card, remove the four screws located in the corners of the card, and disconnect the battery, signal cable, and the switchplate.

C. **Recalibration**

In order to provide maximum accuracy, the MC-II should be recalibrated whenever its associated flow meter has a new rotor and vane kit installed, or whenever the MC-II is used with a flow meter with a different calibration factor. Changing the calibration of an MC-II will not destroy the total accumulated flow up to that time. Additional flow will be added to that total based on the new calibration information.

Calibration

The MC-II Flow Analyzer is capable of several different operating modes. Each MC-II shipped is set to the mode of operation specified on the order. It is possible to change the mode of operation in the field if necessary. The MC-II Flow Analyzer comes factory calibrated to match its companion flow meter which should make field calibration unnecessary. However, if calibration adjustment is required, it can be performed at the job site (see Figure 4, page 26).

A. **Mode of Operation**

Three different functions are controlled by jumper plugs on the MC-II circuit board. These functions are the ability to calibrate, the ability to reset, and the ability to enter a rate multiplier. Refer to Figure 4, page 26, for the location of each of these jumpers.

1. **Calibrate**

The calibrate jumper enables or disables the ability to calibrate the MC-II from the front panel without opening the enclosure. If the operator wants to be able to calibrate the MC-II from the front panel at all times, the jumper should be placed in the ENABLE position. If the operator does not want to have calibration abilities available via the front panel, the jumper should be placed in the DISABLE position. If the jumper is in the DISABLE position, the MC-II must be opened and the jumper plug placed in the ENABLE position in order to calibrate the unit. The jumper can be returned to the DISABLE position after calibration is complete.

2. **Reset**

The reset jumper enables or disables the ability to reset the MC-II totals display to zero from the front panel without opening the enclosure. If the operator wishes to be able to reset the MC-II from the front panel, the jumper should be placed in the ENABLE position. If the operator does not want to have reset capabilities continuously available at the front panel, the jumper should be placed in the DISABLE position. The MC-II must be opened and the jumper plug placed in the ENABLE position in order to reset the totals display.

3. **Rate Multiplier**

The MC-II can calculate a rate multiplier for use in determining flow rate if the time base reflects units per day. It is possible to enter another multiplier if other

units of measure are required or if a more accurate multiplier for units per day is desired. If the operator wants the MC-II to calculate the rate multiplier, the one number calibration (ONC) jumper should be placed in the ENABLE position. If the operator prefers to enter the rate multiplier, the ONC jumper should be placed in the DISABLE position. Refer to the Rate Multiplier Calculation Section, page 6, for more information.

B. Divisor Calculation

The signal from the flow meter used with the MC-II is amplified and squared by the electronic circuitry. The divisor, which is the number of flow meter pulses per unit of volume, is programmed into the MC-II. By making continuous calculations based on the number of stored pulses and the divisor, the MC-II generates total volume readings.

1. Liquid Flow Meters

The divisor for a liquid meter is determined by the flow meter calibration factor and the appropriate conversion factor for the desired units of registration (see MC-II Calibration Examples, page 8).

2. Gas Flow Meters

The divisor for a gas meter is determined by the flow meter calibration factor and the appropriate conversion factor for the desired units of registration. It is also generally desirable to compensate the divisor in order to measure gas in terms of standard unit volumes instead of actual unit volumes. Volumes measured by gas meters are affected by temperature and pressure. If the flowing temperature and pressure are constant, it is possible to adjust the divisor for registration of standard unit volumes by using the following equation (see MC-II Calibration Examples, page 9).

$$Divisor = \frac{FC \times P_s \times T_f}{P_f \times T_s}$$

Where

- FC = Flow Meter Calibration Factor (Pulses/ACF)
- P_s = Standard Pressure = 14.73 PSIA
- P_f = Flow Pressure (PSIA)
- T_f = Flowing Temperature (°R)
- T_s = Standard Temperature = 519.67 (°R)

Degrees Rankine = Degrees Fahrenheit + 459.67

PSIA = PSIG + atmospheric pressure at metering site (14.73 at sea level)

C. Divisor Entry

Once the proper divisor has been calculated, it may be entered into the MC-II by use of the membrane switches on the front of the unit. To begin the divisor entry routine, simultaneously press the **Access** and **Enter/Step** buttons. Calibrate jumper must be in "enable" position (refer to Calibration Section A, page 4.) Both displays will clear except for a single zero in the right-hand side of the total display. Press the **Increment** button repeatedly until the number in that position equals the number in the right-most digit of the divisor. (Divisor must be entered from right to left.) Press the **Enter/Step** button. A zero will appear in the next higher digit of the display. Again, use the **Increment** button to obtain a number in this position corresponding to that in the divisor. Repeat this process until all of the digits of the divisor are entered. Note that it may be necessary to enter zeroes to the left in the case of smaller digits.

When the five digit positions of the divisor display have been entered and the **Enter/Step** button pressed after the fifth entry, an "L" will appear in the total display. This is a prompt asking for the decimal point to be set. Pressing the **Dec. Point** button repeatedly will cause the decimal point to loop through positions for tenths, hundredths, thousandths, and whole numbers. When the decimal point is in the position corresponding to that required for the units of registration determined by the divisor, press the **Enter/Step** button.

After the decimal point has been entered, the MC-II will begin operation if it has been programmed for a one-number calibration. If it has been programmed for a two-number calibration, a zero will appear in the right-hand digit of the rate display, indicating the need to enter a rate multiplier.

D. Rate Multiplier Calculation

The rate multiplier is the number which will yield the desired flow rate reading when multiplied by the flow meter frequency. This number will be automatically calculated for the selected volumetric units (barrels) per day when the MC-II is in one-number calibration mode. (NOTE: Some instances exist in which it would not be desirable to use the one-number calibration mode. Refer to Table I, page 7.) When rate readings other than volume per day are required, or when greater accuracy is required, the one-number calibration should be disabled in order that the multiplier may be entered by the user. The rate multiplier is calculated as follows:

$$\text{Rate Multiplier} = \frac{TC}{(FC \times CON)}$$

Where TC = Time Conversion (Second/Unit Time)
 FC = Flow Meter Calibration Factor (Pulses/Gallon)
 CON = Conversion Factor (Gallon/Unit Volume)

The number FCxCON will be the number of pulses per whole unit volume and thus will not necessarily be the same as the divisor. For example, an MC-II used with a 1" turbine meter and indicating barrels and barrels per day could have a divisor of 3781 (i.e. each count is .1 barrel, see Example B, page 8) and a rate multiplier of:

$$\frac{86,400 \text{Seconds} / \text{Day}}{900.21 \text{PUL} / \text{GAL} \times 42 \text{GAL} / \text{BBL}} = 2.285$$

Note that even though the divisor is set for .1 barrels, the rate multiplier is still calculated based on pulses per whole barrel.

E. Rate Multiplier Entry

Once the rate multiplier has been calculated, it may be entered into the MC-II by using the membrane switches on the front of the unit in a manner very similar to that used to enter the divisor. The divisor must always be entered before the rate multiplier may be entered or changed (see Divisor Entry Section, page 5).

The rate multiplier entry begins with a zero in the right-hand digit of the rate **Enter/Step** display. Press the **Increment** button repeatedly until the number in that position equals the number in the corresponding digit of the rate multiplier. Press the " " button. A zero will appear in the next higher digit of the display. Again use the **Increment** button to obtain a number in this position corresponding to that in the rate multiplier. Repeat this

process until all digits of the rate multiplier are entered. Note that it may be necessary to enter zeroes in the upper positions in the case of small rate multipliers, because only three places to the right of the decimal point may be entered.

When the five-digit rate multiplier has been entered and the **Enter/Step** button pressed after the fifth entry, an "L" will appear in the rate display. This is a prompt asking for the decimal point to be set. The purpose of decimal point positioning for the rate multiplier is different than that of the divisor. The decimal point in the divisor routine was placed in the position that it was to appear in the total display. The decimal point in this routine is to be positioned where it actually occurs in the rate multiplier. Press the **Dec. Point** button repeatedly to loop the decimal point through the positions for tenths, hundredths, thousandths, and whole numbers. When the decimal point is in the position corresponding to that of the decimal point in the rate multiplier, press the **Enter/Step** button. After this entry, the MC-II will begin operation.

Table 1

Maximum Size of Rate Multiplier Entry

Meter	GPM	GPH	GPD	BPM	BPH	BPD	M3/Mi n	M3/H	M3/D
3/8"	.XXX*	.XXX*	X.XXX	+ *	.XXX*	.XXX	+ *	+ *	.XXX*
1/2"	.XXX*	.XXX*	X.XXX	+ *	.XXX*	.XXX	+ *	+ *	.XXX*
3/4"	.XXX*	X.XXX*	XX.XX	+ *	.XXX*	.XXX	+ *	.XXX*	.XXX
1"	.XXX*	X.XXX*	XX.XX	.XXX*	.XXX*	X.XXX	+ *	.XXX*	.XXX
1 1/2"	.XXX*	XX.XXX*	XX.*	.XXX*	.XXX*	X.XXX	+ *	.XXX*	.XXX
2"	X.XXX*	XX.XXX*	XXX.*	.XXX*	X.XXX*	XX.XXX	.XXX*	.XXX*	X.XXX
3"	X.XXX*	XX.XXX*	XXX.*	.XXX*	X.XXX*	XX.XX	.XXX*	.XXX*	X.XXX
4"	X.XXX*	XXX.XX*	XX.*	.XXX*	X.XXX*	XX.XX	.XXX*	.XXX*	XX.XXX
6"	X.XXX*	XX.*	XXX.*	.XXX*	XX.XXX*	XX.*	.XXX*	X.XXX*	XX.XXX
8"	XX.XXX*	XXX.*	XXX.*	.XXX*	XX.XXX*	XX.*	.XXX*	X.XXX*	XXX.XX

+ Due to very small size of rate multiplier (less than .001), reading rate in these units is not recommended with this meter.

* One-number calibration should not be used.

F. MC-II Calibration Examples

Basic information needed before starting:

STEP 1. You will need the calibration factor for the turbine flow meter. This factor will be in pulses per gallon, except for gas meters which are in pulses per actual cubic foot. The factor can be found written on the plastic tag located around the pickup adapter on the flow meter body. If you have this information, proceed to STEP 2- if not, call NuFlo Measurement Systems at 1-800-654-3760 with the serial number of the flow meter body. **Note: Each NuFlo turbine flow meter has a unique calibration factor.**

STEP 2. Apply the calibration factor of the turbine flow meter to one of the following situations:

A.	3/8" or 1/2" meter	Total = Barrels	Rate = BPD
B.	3/4", 7/8" or 1" meter	Total = Barrels	Rate = BPD
C.	1-1/2" thru 4" meter	Total = Barrels	Rate = BPD
D.	1-1/2" meter	Total = Barrels	Rate = BPM
E.	3/8" thru 4" meter	Total = Gallons	Rate = GPM
F.	6" and 8" meter	Total = Gallons	Rate = GPM
G.	2" gas meter	Total = MCF	Rate = MCF/Day
H.	1-1/2" meter	Total = Cubic Meters	Rate = M ³ /Day
I.	1-1/2" meter	Total = Pounds	Rate = lb/Min

If your application is not covered by one of these examples, contact NuFlo Measurement Systems. If your application is covered, proceed to the paragraph indicated by the capital letter matching your application. Go through the steps in that paragraph, doing the necessary calculation, then proceed to STEP 3.

A. 3/8" meter factor = 20,341 pulses/gallon
 $20,341 \text{ pulses/gallon} \times 42 \text{ gallons/barrel} = 854322 \text{ pulses/barrel}$
(maximum allowable divisor for whole units is 32767)
Round off last two digits and add a decimal point to the display
MC-II divisor = 8543 with a decimal point in the .00 position (top display)
Since rate is in Per Day, the rate multiplier will be calculated for you if the ONC jumper is enabled. Go to STEP 3.

B. 1" meter factor = 900.21 pulses/gallon
 $900.21 \text{ pulses/gallon} \times 42 \text{ gallons/barrel} = 37808.82 \text{ pulses/barrel}$
Round 37808.82 to nearest whole number = 37809
(maximum allowable divisor for whole units is 32767)
Round off last digit and add a decimal point to the display
MC-II divisor = 3781 with a decimal point in the .0 position (top display)
Since rate is in Per Day, the rate multiplier will be calculated for you if the ONC jumper is enabled. Go to STEP 3.

C. 2" meter factor = 56.24 pulses/gallon
 $56.24 \text{ pulses/gallon} \times 42 \text{ gallons/barrel} = 2362.08 \text{ pulses/barrel}$
Round to nearest whole number 2362 (whole number less than 32767)
MC-II divisor = 2362 with no decimal (top display)
Since rate is Per Day, the rate multiplier will be calculated for you if the ONC jumper is enabled. Go to STEP 3.

- D. 1-1/2" meter factor = 332.67 pulses/gallon
 332.67 pulses/gallon x 42 gallons/barrel = 13972.14 pulses/barrel
 Round to whole number 13972 (whole number less than 32767)
 MC-II divisor = 13972 with no decimal (top display)
 Since rate is Per Minute, a rate multiplier must be calculated and entered.
 ONC jumper must be disabled.
 60 seconds/minute divided by 13972.14 pulses/barrel = .0042943
 (maximum positions to the right of the decimal point is 3)
 MC-II Rate Multiplier = .004 after round off (bottom display)
 Go to STEP 4.
- E. 7/8" meter factor = 2225.69 pulses/gallon
 No conversion needed for divisor
 Round to nearest whole number 2226 (whole number is less than 32767)
 MC-II divisor = 2226 with no decimal (top display)
 Since rate is Per Minute, a rate multiplier must be calculated and entered.
 ONC jumper must be disabled
 60 seconds/minute divided by 2225.69 pulses/gallon = .0269579
 (maximum positions to the right of the decimal point is 3)
 MC-II Rate Multiplier = .027 after round off (bottom display)
 Go to STEP 4.
- F. 6" meter factor = 6.97 pulses/gallon
 A 6-inch meter has a full scale flow rate of 2500 GPM
 Full Scale Frequency = (2500 gallons/minute divided by 60 seconds/minute) x 6.97
 pulses/gallon) = 290 pulses/second (Freq.)
 Count Rate/second = 290 pulses/second divided by 6.97 pulses/gallon = 41.61
 counts/second (maximum counts/second is 35)
 Increase meter factor by a factor of 10 or 100
 Count Rate/second = 290 pulses/second divided by 69.7 pulses/gallon = 4.161
 counts/second (count rate/second below 35)
 Round to nearest whole number 70 (add label to display GALLONS x 10)
 MC-II divisor = 70 (add label to faceplate GALLONS x 10)
 Since rate is Per Minute, a rate multiplier must be calculated and entered.
 ONC jumper must be disabled.
 60 second/minute divided by 6.97 pulses/gallon = 8.6083214
 (maximum positions to the right of decimal is 2)
 MC-II Rate Multiplier = 8.61
 Go to STEP 4.
- G. 2" gas meter factor = 127.62 pulses/actual cubic foot
 Operating pressure is a constant 55 psig
 Operating temperature is 80 degrees F

Local atmospheric pressure 12.73
 (standard conditions are 60 deg F and 14.73 psia)
 The following equation is shown with temperature compensation:

$$\frac{(P / ACF \times 14.73 \text{ PSIA}) \times (\text{OPER. TEMP.} + 459.67 \text{ deg Rankine})}{(\text{OPER. PRES.} + 12.73 \text{ PSIA}) \times (459.67 \text{ deg R} + 60 \text{ deg R})}$$

$$\frac{(127.62 \times 14.73) \times (80 + 459.67)}{(55 + 12.73) \times (519.67)}$$

MC-II Flow Analyzer

$$\frac{1879.8426 \times 539.67}{67.73 \times 519.67}$$

$$67.73 \times 519.67$$

= 28.823123 pulses per standard cubic foot (P/SCF)

$$28.823123 \times 1000 = 28823.123 \text{ P/MCF}$$

Round to whole number 28823

MC-II divisor = 28823 with no decimal point in the display (top display)

Since rate is Per Day, the rate multiplier will be calculated for you if the ONC jumper is enabled.

Go to STEP 3.

- H. 1-1/2" meter factor = 331.26 pulses per gallon
 331.26 pulses per gallon x 264.2 gallons/cubic meter = 87518.892 pulses/cubic meter
 Round to nearest whole number 87519
 (maximum allowable divisor for whole units is 32767)
 Round off last digit and add a decimal point to the display
 MC-II divisor = 8752 with a decimal point in the .0 position (top display)
 Since rate is in Per Day, the rate multiplier will be calculated for you if the ONC jumper is enabled.
 Go to STEP 3.

- I. 1-1/2" meter factor = 329.86 pulses per gallon
 The material being pumped weighs 7.95 pounds per gallon
 329.86 pulses per gallon divided by 7.95 pounds per gallon = 41.491824 pulses per pound
 Round to whole number 42
 MC-II divisor = 42 (top display)
 Since rate is Per Minute, a rate multiplier must be calculated and entered.
 ONC jumper must be disabled
 60 seconds per minute divided by 41.491824 pulses per pound = 1.446068
 (maximum positions to the right of decimal is 3)
 MC-II Rate Multiplier = 1.446
 Go to STEP 4.

STEP 3. Entering the divisor when rate is in Per Day (ONE-NUMBER CALIBRATION). If rate is other than Per Day, go to STEP 4.

- A. Loosen the eight screws on the back of the MC-II. Open the MC-II up by tilting the face plate assembly forward. Check the jumpers on the bottom of the circuit card edge next to the enclosure. They should be in this position:

O	o	o	o	o	o	ONC= enabled (one-number calibration) RST = disabled (front panel reset) CAL = enabled (calibration mode)
O	o	o	o	o	o	
C		F		L		
Z		S		A		
O		R		C		

Blank pins are storage positions for jumpers.

If the ONC and CAL jumpers are not in these positions, move them now. This will enable one-number calibration and calibration mode.

B. Next place the MC-II in calibration mode by pressing the **Enter/Step** and **Access** buttons at the same time. The displays will go blank and a single zero will appear on the right-hand side of the top display. (Note: During the calibration procedure, total accumulated counts are kept. Total accumulation can only be removed by enabling the front panel reset or by disconnecting the battery. Battery disconnection will also lose calibration information and when reconnected, unit will be in calibration mode by default.)

C. The divisor must be entered from right to left.

Example: 1-inch meter in barrels and BPD
 Meter factor 902.07 pulses per gallon
 Divisor = 3789 with a decimal in the tenths (.0) position

Start

Press **Increment** button until a 9 appears in place of the zero. (9 times)

Press **Enter** (1 time)

Press **Increment** button until an 8 appears in place of the zero. (8 times)

Press **Enter** (1 time)

Press **Increment** button until a 7 appears in place of the zero. (7 times)

Press **Enter** (1 time)

Press **Increment** button until a 3 appears in place of the zero. (3 times)

Press **Enter** (1 time)

Press **Enter** (1 time)

This is where a decimal point is entered if required. If no decimal is required, press **Enter** again. (This example requires a fixed decimal in the tenths (.0) position to appear on the display at all times. While the **L** is on the display, press the **Dec. Point** button one time.

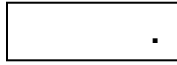

Press **Enter** (1 time)

The unit is now in run mode.

The display will show the total accumulated volume in the top display that was there before calibration mode was activated and zeroes in the bottom display if there is no flow. A rate will appear if there is flow through the turbine meter.

Press and hold the **View Div.** button. The top display will show a divisor of 3789 with a fixed decimal point in the tenths (.0) position. (Divisor and decimal location are shown at the same time.)

top 378.9

bottom 2.28

The bottom display will show the rate multiplier that has been internally calculated. (If you use the numbers in this example, the displays will show the above numbers.)

You have now completed the calibration of the MC-II for one-number calibration and a rate in Per Day.

STEP 4. Entering a divisor and a calculated rate multiplier.

- A. Loosen the eight screws on the back of the MC-II. Open the MC-II by tilting the faceplate assembly forward. Check the jumpers on the bottom of the circuit card edge next to the enclosure. They should be in this position:

o	o	o	o	o	o	ONC= disabled (one-number calibration) RST = disabled (front panel reset) CAL = enabled (calibration mode)
o	o	o	o	o	o	
C	T	L				
Z	S	A				
O	R	C				

Blank pins are storage positions for jumpers. If the ONC and CAL jumpers are not in these positions, move them now. This will disable one-number calibration and enable calibration mode. When the ONC jumper is disabled, a rate multiplier entry is required.

- B. Next, place the MC-II in calibration mode by pressing the **Enter/Step** and **Access** buttons at the same time. The displays will go blank and a single zero will appear on the right-hand side of the top display. (Note: During the calibration procedure, total accumulated counts are kept. Total accumulation can

only be removed by enabling the front panel reset or by disconnecting the battery. Battery disconnection will also lose calibration information and when reconnected, unit will be in calibration mode by default.)

- C. The divisor and rate multiplier must be entered from right to left, with the divisor being entered first in the top display and the rate multiplier being entered second in the bottom display.

Example: 1-inch meter in gallons and GPM
Meter factor 902.07 pulses per gallon
Divisor = 902 with no decimal
Rate Multiplier = 60 divided by 902.07 = .0665 (round off to .067)

Start

Press **Increment** button until a 2 appears in place of the zero. (2 times)

Press **Enter** (1 time)

Press **Enter** (1 time)

Press **Increment** button until a 9 appears in place of the zero. (9 times)

Press **Enter** (1 time)

Press **Enter** (1 time)

Press **Enter** (1 time)

This is where a decimal point is entered if required. If no decimal is required, press **Enter** again. (This example requires no decimal point in the top display.)

The top display will go blank and a single zero will appear on the right-hand side of the bottom display.

RATE MULTIPLIER ENTRY

Start

Press **Increment** button until a 7 appears in place of the zero. (7 times)

Press **Enter** (1 time)

Press **Increment** button until a 6 appears in place of the zero. (6 times)

Press **Enter** (1 time)

Press **Enter** (1 time)

Press **Enter** (1 time)

Press **Enter** (1 time)

This is where a decimal point is entered if required. If no decimal is required, press **Enter** again. (This example requires a decimal in the thousandths (.000) position.

While the **L** is on the display, press the **Dec. Point** button three (3) times.

NOTE: This is a floating decimal and will move as the rate changes.

Press **Enter** (1 time)

The unit is now in run mode.

The display will show the total accumulated volume in the top display that was there before calibration mode was activated and zeroes in the bottom display if there is no flow. A rate will appear if there is flow through the turbine meter.

Press and hold the **View Div.** button. The top display will show a divisor of 902 with no decimal. (NOTE: Divisor and decimal location, if set, are shown at the same time.)

top

902

bottom

.067

The bottom display will show the rate multiplier that you have entered. (If you use the numbers in this example, the displays will show the above numbers.)

You have now completed the calibration of the MC-II for two-number calibration.

Sensitivity Adjustment - Flow Meter Signal

The circuit assembly for the MC-II has a feature that allows adjustment of the sensitivity for the flow meter input signal.

Provided on the circuit assembly is a 25-turn, 5000 ohm potentiometer. Adjustment of this "pot" varies the sensitivity range from approximately 950 mV p-p down to 15 mV p-p. Instruments are factory set at 20 mV p-p. See Nomenclature II, page ii, for location of this potentiometer.

A clockwise adjustment will increase the sensitivity, allowing a signal with less amplitude to operate the unit. Caution should be used here in order that the sensitivity not be adjusted so low that electrical noise would be counted along with the signal pulses.

A counter-clockwise adjustment will decrease the sensitivity. In other words, a larger input signal would be required to operate the unit. Some electrically "noisy" areas may require that this adjustment be done, in order to eliminate the noise from the signal processing.

RECOMMENDED SPARE PARTS LIST

<u>Quantity</u>	<u>Part Number</u>	<u>Description</u>
1	100005109	Circuit Assembly-Totalizer/Rate Indicator-LCD
1	100005111	Battery
1	100002605	Vapor Capsule
1	100005116	1 ft. Cable Assembly
1	100005118	Front Panel with Keypad Switch
1	100005126	Sponge Rubber Gasket
*1	100005117	10 ft. Cable Assembly
**1	100005121	Circuit - Pulse Output
***1	100005163	Circuit - Pulse Output - Intrinsically Safe
****1	100034876	Relay - Pulse Output - 5V
****1	100002361	Relay - Pulse Output - 12V
****1	100002551	Relay - Pulse Output - 24V
****1	100079680	Module - Open Collector Pulse Output
****1	100007975	Module - Opto-Isolated Pulse Output

- * Required with remote mounting option.
- ** Required with pulse output option.
- *** Required with intrinsically safe pulse output option.
- **** Check specific MC-II assembly to determine which pulse out relay or module is required.

Options

1. Totalizer and Flow Rate Units

The MC-II Flow Analyzer's standard configuration is for increments of barrels (BBL) and barrels per day (BPD). Other totalizer units and flow rate units are available and should be specified when ordering. It is possible to change the units of measurement in the field (see Calibration Section, page 4, for instructions).

2. Totalizer Reset

The MC-II Flow Analyzer is furnished with the totalizer reset switch on the front panel disabled so that pressing this switch will not reset the totals display, unless the **Reset** option is specified at the time the instrument is ordered. This feature may be enabled in the field to allow the totals display to be reset from the front panel.

3. Remote Mounting

The MC-II Flow Analyzer is normally furnished for flow meter mounting. Optional hardware, including additional signal cable, is available for pipe mounting (refer to Figure 2, page 24). The remote mounting option kit consists of a mounting bracket, "U" bolts, nuts and lock washers, weatherproof adapter and 10-ft. signal cable assembly. Additional signal cable length is available if required.

- A. If remote mounting option was specified at the time the instrument was ordered, follow Step 1 below only.
- B. If the remote mounting option was not specified when the MC-II Flow Analyzer was originally ordered, skip Step 1 below and proceed directly to Steps 2, 3, and 4.

Step 1: Place the "U" bolts around the pipe the MC-II is to be mounted on, then through the mounting bracket. Note that the holes in the mounting bracket are arranged such that it may be used with horizontal or vertical pipe. (Note: Disregard the center hole in the mounting bracket.) Fasten the bracket with the lock washers and nuts. Use the bolts, lock washers and nuts to attach the MC-II to the bracket. Position the MC-II to the viewing angle desired before tightening the nut. Follow the installation procedure of the weatherproof pickup housing furnished with the flow meter.

Step 2: To remove old cable connector, loosen the eight captive screws around the outer edge on the back of the enclosure. Once all of these screws are loose, the front plate of the MC-II folds down, hinging on the plastic retaining straps at the bottom of the enclosure. The cable feeds through the rubber grommet to the inside of the enclosure where it is connected to the terminal connector (see Nomenclature II, page ii). Unscrew terminal connector number 3 and pull off the black cable lead, then unscrew terminal connector number 4 and pull off the red or white cable lead. Cut cable tie on the cable and pull the cable through the housing.

CAUTION: Under normal operating conditions the MC-II poses no hazard when the enclosure is opened. The lithium battery which powers the MC-II is a sealed unit; but if one of these units leaks, there is a possibility of toxic fumes being present when the enclosure is opened. Select a well-ventilated area in which to open the enclosure and avoid breathing fumes that may be trapped inside. Care must be taken in handling and disposing of a damaged battery (see Appendix Section for additional safety information).

Step 3: To install new cable connector, feed cable through rubber grommet and make a knot or install a cable tie inside housing, allowing enough free length to connect wires to the terminal connector. Feed black lead and shield into terminal connector number 3 and screw retainer down tight. Feed red or white lead into terminal connector number 4 and screw retainer down tight. Close the enclosure and retighten all 8 screws. Follow the installation procedure of the weatherproof pickup housing furnished with the flow meter.

Step 4: To mount the bracket, place the "U" bolts around the pipe the MC-II is to be mounted on, then through the mounting bracket. Note that the holes in the mounting bracket are arranged such that it may be used with horizontal or vertical pipe. (Disregard the center hole in the mounting bracket.) Fasten the bracket with the lock washers and nuts. Remove the nut and bolt which holds the MC-II housing to the upper mount. Discard the mount but use the bolt, lock washer, and nut to attach the MC-II to the bracket. Position the MC-II to the viewing angle desired before tightening the nut.

4. Two-Number Calibration

The MC-II Flow Analyzer is furnished with ONC (one-number calibration), unless the two-number calibration option is specified at the time the instrument is ordered. The two-number calibration feature permits the operator to enter the totalizer divisor and the rate multiplier for the selected units per day.

5. Calibration From Front Panel

The MC-II Flow Analyzer is furnished with calibration from the front panel disabled, unless this feature is requested to be enabled at the time the instrument is ordered. Having this feature enabled allows the operator to calibrate the MC-II via the front panel without having to open the instrument and move the calibration jumper to the "enable" position.

6. MC-II Pulse Output Circuit Assembly - Part No. 100005121

This circuit assembly was designed for use with the MC-II Flow Analyzer to provide optional pulse output. It is mounted inside the unit between the totalizer board and the battery cavity. A 6-pin terminal strip and two mounting holes allow for easy installation.

The following paragraphs describe the circuit assembly's operation:

A. Pulse Input

The pulse input to this card is obtained from the "Pulse Out" of the totalizer card. It will appear in the form of a single square wave pulse or a "burst" of several pulses, according to the flow meter input frequency and divisor setting on the totalizer board.

B. Pulse Output

The pulse output from this card is provided in the form of a dry contact from a relay, transistor open-collector, or an emitter/collector opto-isolated output. A 14-pin socket on the card is provided to install either the relay or component plug "module", whichever is specified.

C. Divide-By-Circuit

The "W1" jumper is used to select whether the output is to occur with each increment of the totalizer volume, for every 10 increments, or for every 100 increments of the display total. In most cases, either divide-by-1, divide-by-10, or divide-by-100 can be selected with no problem of losing pulse output counts. However, due to the totalizer display update time being approximately 2.8 seconds and its "burst" potential of pulses, there may be times when the divide-by-10 or divide-by-100 mode is mandatory to maintain proper pulse out to incremental volume ratio. In order to determine whether this is necessary, divide the calculated divisor by the flow meter's maximum frequency. This value can then be looked up in Table 2 below to determine which jumper position can be selected.

Table 2	
Divisor/Frequency	Pulse Output ("W1" Jumper)
.028 to .27	Use divide-by-100 only
.28 to 2.7	Use divide-by-10 or 100
2.8 & up	Use divide-by-1, 10 or 100

D. External Power Input

The DC power input to this card can range from a fixed 5V to 28V. However, 12V or 24V is preferred. Five volt, 12V and 24V relays are standard and available for this circuit.

Any other voltage may require that the "W2" jumper be replaced with a resistor. This would serve to limit current through the relay coil should a "non-standard" input voltage be selected. If 5 volts were selected as the supply voltage, the circuit card would have to be modified as follows:

- (1) Remove CR3 and VR1.
- (2) Install jumper wire in CR3 position.
- (3) Install jumper wire from 1st to 3rd pins of VR1 position.
- (4) Install 5V relay.

E. External Power of Totalizer Board

Normally, the lithium battery within the MC-II provides power to the totalizer board whether a pulse output board has been installed or not. However, if desired, the battery can be removed and the totalizer board be powered from the pulse output board. To do so would require the following circuit assembly wiring modifications:

- (1) Refer to Installation Drawing, Figure 6, page 27.
- (2) Install R7 (220 ohm), C6 (10 mfd), and CR1 (1N5227) on circuit 100005121 (Figure 5, page 27).
- (3) Remove lithium battery.
- (4) Install wiring assembly from pulse output board J2 to totalizer board J3/J4.

A disadvantage to the above configuration would be that during a power outage, the display totals would be lost and the unit would have to be recalibrated when power was restored.

F. Input/Output Connections (Refer to Figure 7, page 28)

DC Power (12V or 24V preferred)	J1 Pin 6
Ground	J1 Pin 5
Pulse Input & Common	J1 Pin 2,1
Pulse Output - Relay Contact	J1 Pin 4,3
Transistor or Opto-Isolated	J1 Pin 4,3

G. Electrical Specifications

Current Draw	- standard	3 mA
	- with Zener circuit to power totalizer board	10 mA
Relay Contact Rating		0.5, 30 VDC, 10W max (resistive)
Open Collector Module		0.3A max, 30 VDC max
Opto-Isolated Module		0.1A max, 30 VDC max
Pulse Output Duration		60 msec (approx.)

7. MC-II Pulse Output Circuit Assembly - Intrinsically Safe - Part No. 10005163

This circuit assembly was designed for use with the MC-II Flow Analyzer to provide an optional pulse output. It is mounted inside the unit between the totalizer board and the battery cavity. A 6-pin terminal strip and two mounting holes allow for easy installation. When this circuit assembly is installed according to drawing 101231210 (see Figure 9, page 30), the MC-II with pulse output is rated by Underwriters Laboratory and Canadian Standards Association as Intrinsically Safe for Class I, Division 1, Groups A,B,C and D.

The following paragraphs describe the circuit assembly's operation.

A. Pulse Input - Intrinsically Safe

The pulse input to this card is obtained from the "Pulse Out" of the totalizer card. It will appear in the form of a single square wave pulse or a "burst" of several pulses, according to the flow meter input frequency and divisor setting on the totalizer board.

B. Pulse Output - Intrinsically Safe

The pulse output from this card is provided in the form of a dry contact from a relay, transistor open-collector, or an emitter/collector opto-isolated output. A 14-pin socket on the card is provided to install either the relay or component plug "module", whichever is specified.

C. Divide-by Circuit - Intrinsically Safe

The "W1" jumper is used to select whether the output is to occur with each increment of the totalizer volume, for every 10 increments, or for every 100 increments of the display total. In most cases, either "divide-by-1", "divide-by-10" or "divide-by-100" can be selected with no problem of losing pulse output counts. However, due to the totalizer display update time being approximately 2.8 seconds and its "burst" potential of pulses, there may be times when the divide-by-10 or divide-by-100 mode is mandatory to maintain proper pulse out to incremental volume ratio. In order to determine whether this is necessary, divide the calculated "divisor" by the flow meter's maximum frequency. This value can then be looked up in Table 2 (page 19) to determine which jumper position can be selected.

D. External Power Input - Intrinsically Safe

The **DC** power input to this card is 6V.

E. Input/Output Connections - Intrinsically Safe

(Refer to Figure 9, page 30)

DC Power		J1 Pin 6
Ground		J1 Pin 5
Pulse Input & Common		J1 Pin 2,1
Pulse Output	- Relay Contact	J1 Pin 4,3
	- Transistor or Opto-Isolated	J1 Pin 4,3

F. Electrical Specifications - Intrinsically Safe

Current Draw	3 mA
Relay Contact Rating	0.5, 30 VDC, 10W max (resistive)
Open Collector Module	0.3A max, 30 VDC max
Opto-Isolated Module	0.1A max, 30 VDC max
Pulse Output Duration	60 msec (approx)

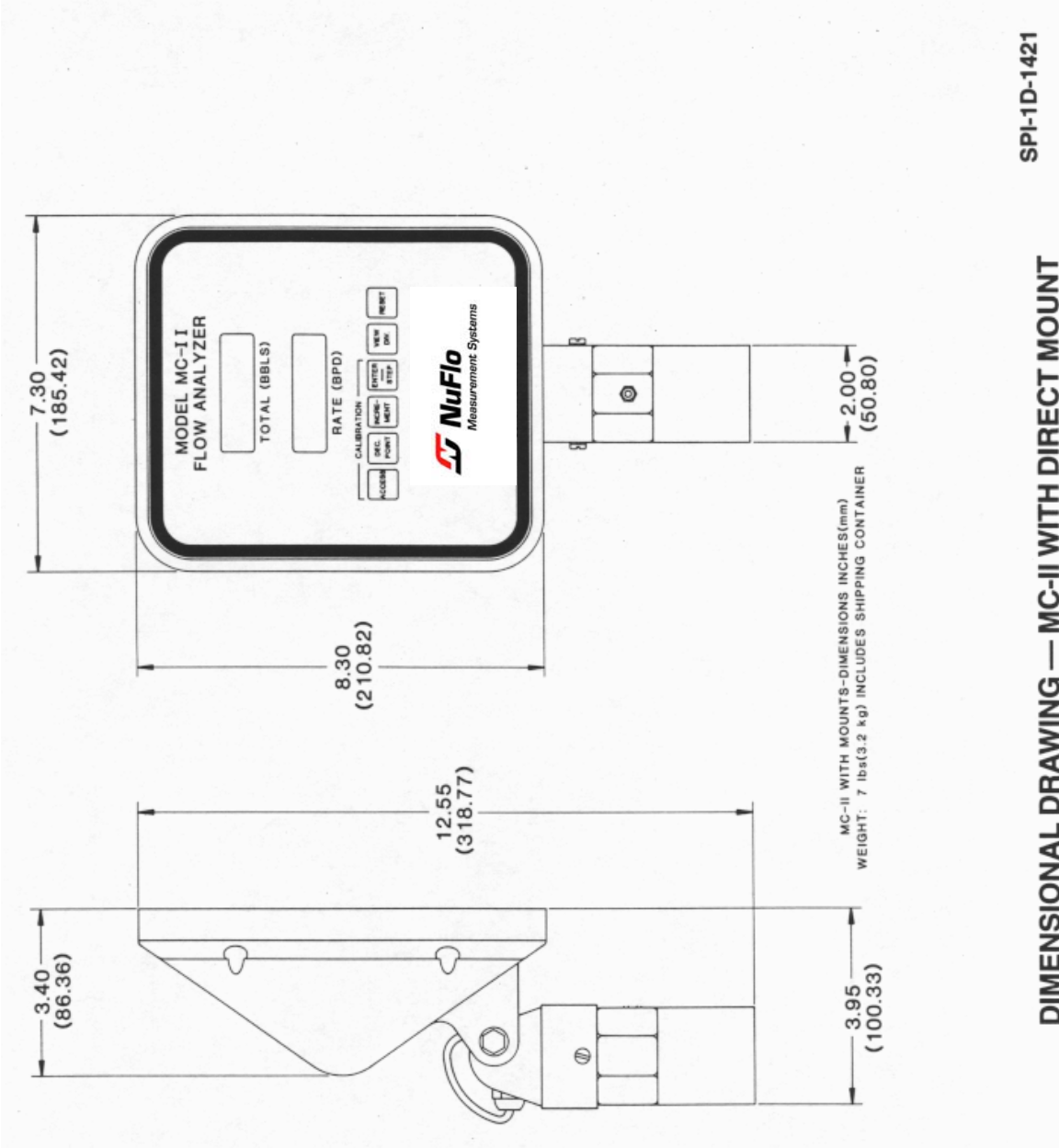

Figure 1

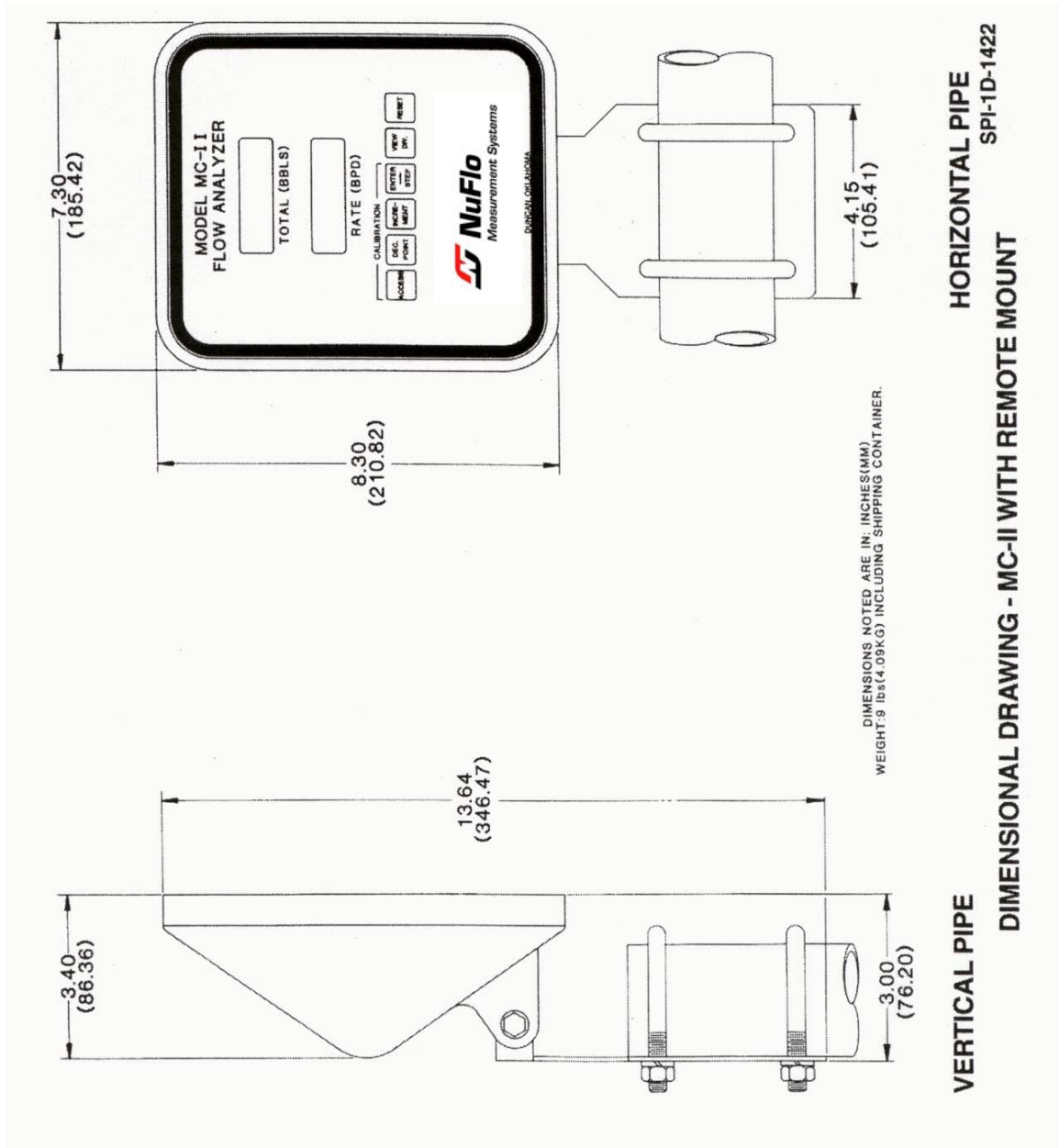

Figure 2

MC-II TOTALIZER BOARD
P.N. 100005109

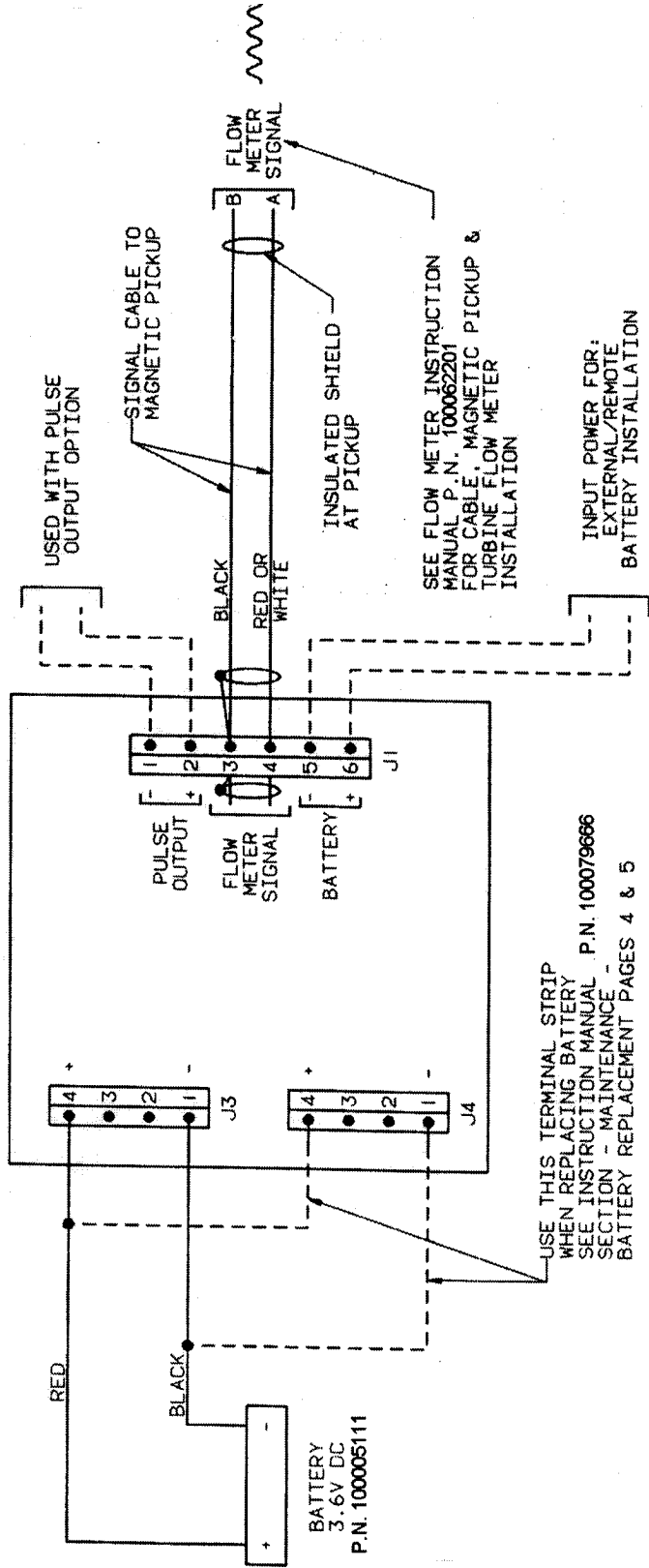
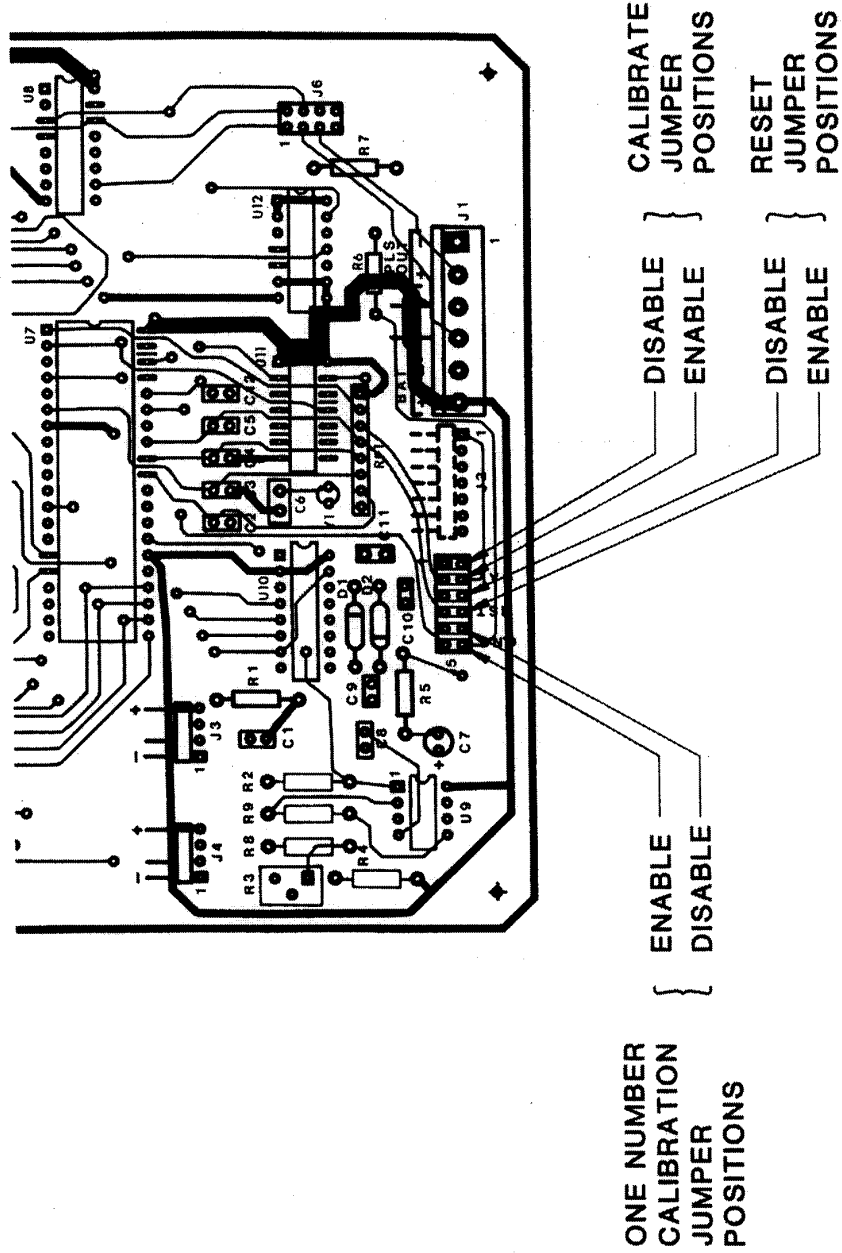

Figure 3

WIRING DIAGRAM



SPI-1C-1179

CALIBRATION JUMPER POSITION

Figure 4

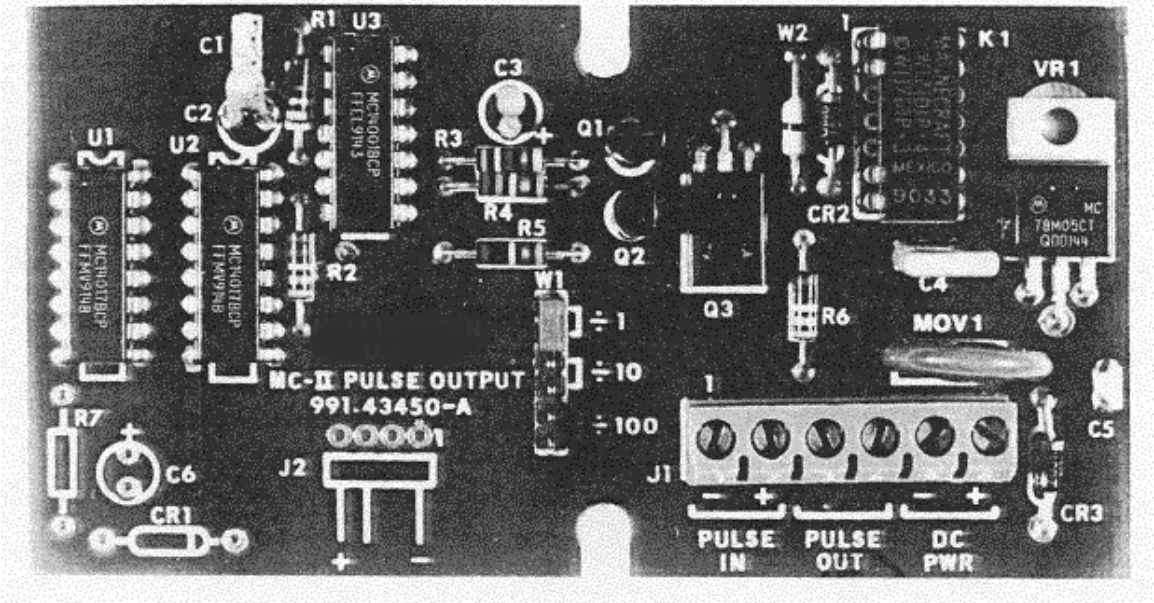

PULSE OUTPUT CIRCUIT ASSEMBLY
P.N. 10005121
Figure 5

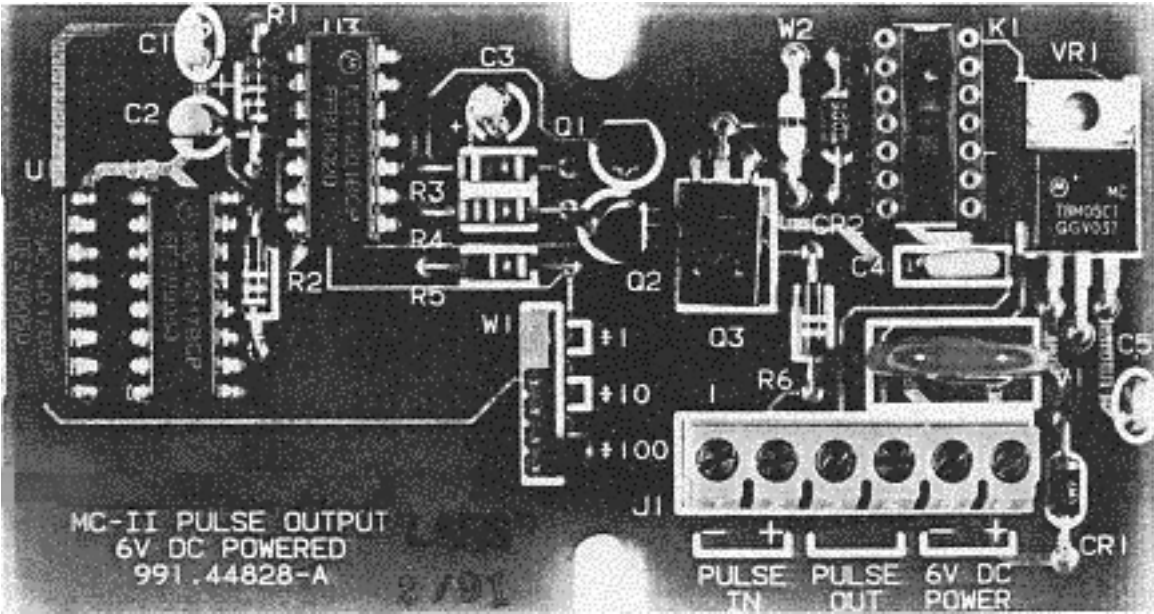

PULSE OUTPUT CIRCUIT ASSEMBLY
INTRINSICALLY SAFE - P.N. 10005163
Figure 6

PULSE OUTPUT OPTION-WIRING & CORD INSTALLATION

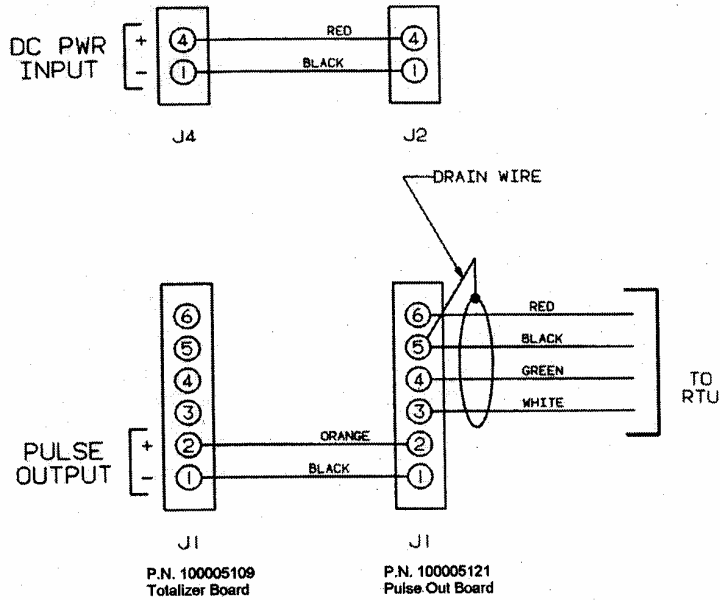

CORD CONNECTOR INSTALLATION

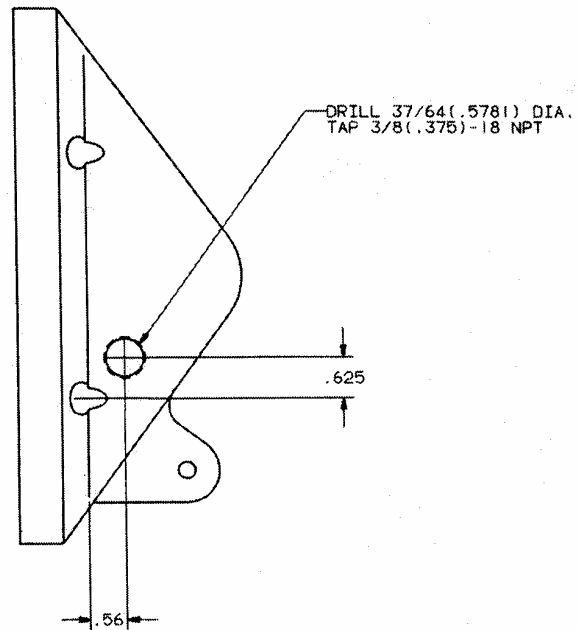
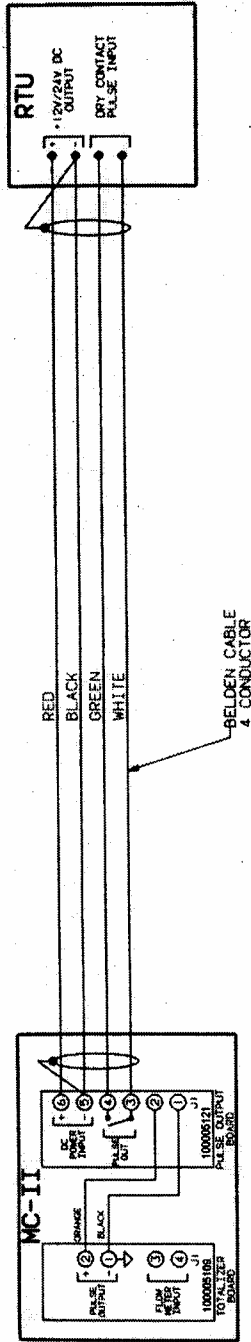
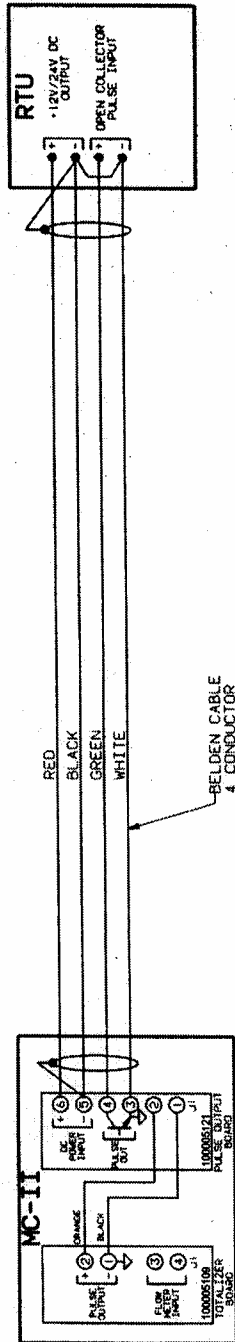

Figure 7

MC-II W/DRY CONTACT PULSE OUTPUT



MC-II W/OPEN COLLECTOR PULSE OUTPUT



MC-II W/OPTO-ISOLATED PULSE OUTPUT

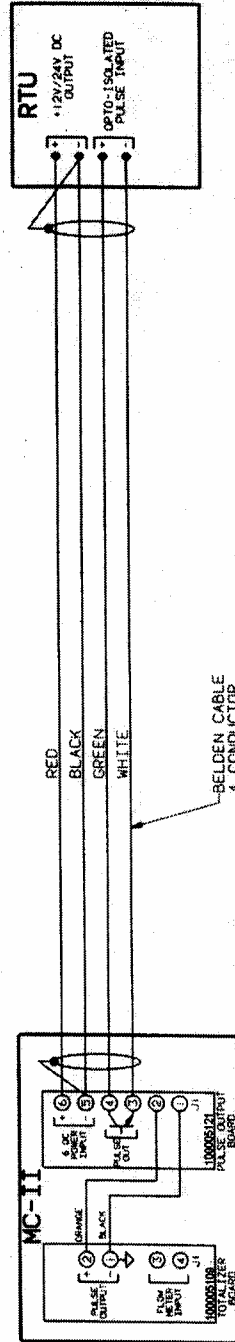

PULSE OUTPUT-INSTALLATION-FIELD WIRING DIAGRAMS:

Figure 8

MC-II WITH DRY CONTACT PULSE OUTPUT

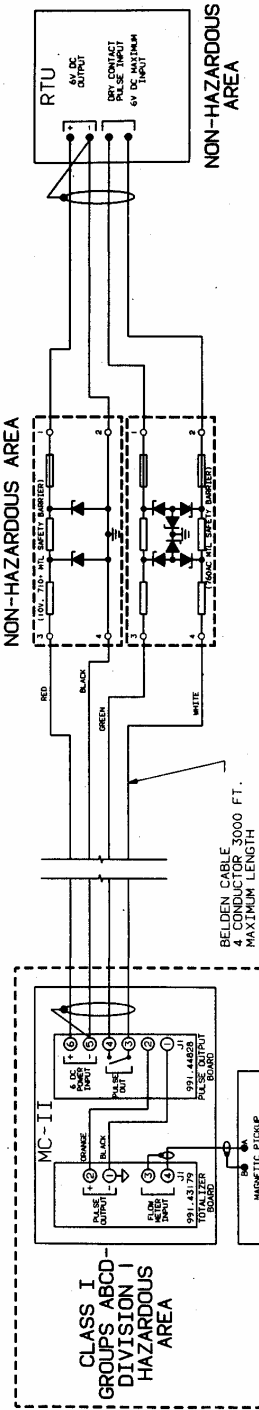

MC-II WITH OPEN COLLECTOR PULSE OUTPUT

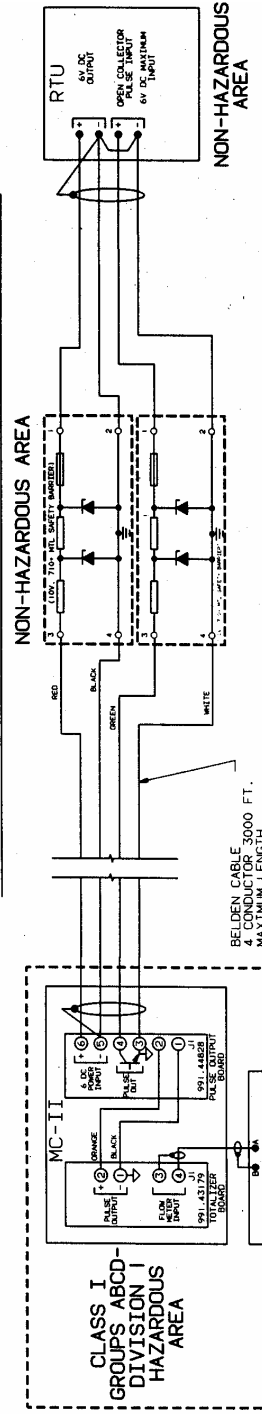

MC-II WITH OPTO-ISOLATED PULSE OUTPUT

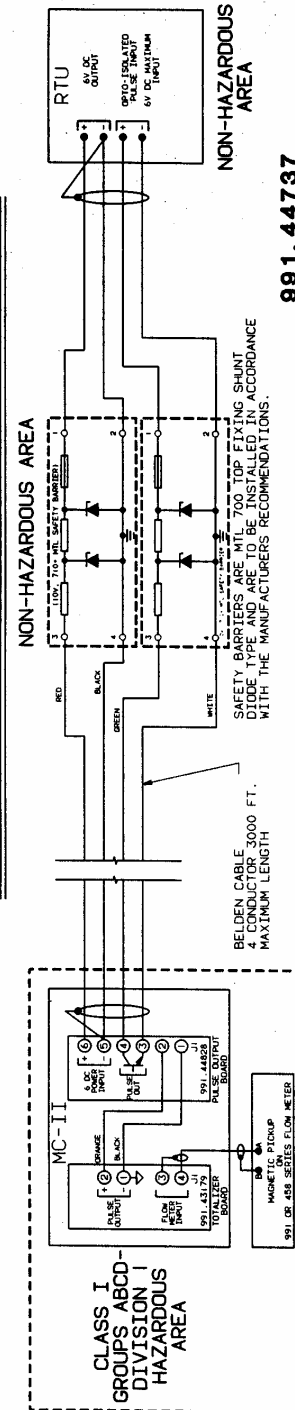

991.44737

Figure 9

Appendix—Lithium Battery Information

Lithium Battery Disposal

Once a lithium battery is spent and removed from a device and/or are destined for disposal, it is classified as solid waste under EPA guidelines. Spent lithium batteries are also considered to be hazardous waste because they meet the definition of Reactivity, as per 40 CFR 261.23(a)(2), (3) and (5). This document describes how the lithium reacts violently with water, forms potentially explosive mixtures with water, and when exposed to certain pH conditions, generates toxic cyanide or sulfide gases.

Since NuFlo Measurement Systems devices containing lithium batteries are used in locations or facilities that would be considered Conditionally Exempt Small Quantity Generators (CESQG – generate less than 100 KG (220 lb) of hazardous waste per calendar month), the batteries are exempt from most of the rules governing hazardous waste. However, one rule that still applies to CESQG's is the requirement that the hazardous waste must be sent to a fully permitted Treatment, Storage and Disposal Facility (TSDF). They can be sent to permitted recycling/reclamation facilities as well.

If the facility where the used batteries were generated is a small quantity generator or large quantity generator, the used lithium batteries are fully regulated as hazardous waste.

Since NuFlo Measurement Systems facilities do not have the necessary permits and cannot feasibly acquire the permits, we cannot accept the used batteries. Facilities that can accept used lithium batteries include the following:

Toxco, Inc.
421 E. Commercial St.
Anaheim, Ca. 92801
Phone: 714-879-2067
Web: <http://www.toxco.com>

Battery Solutions, Inc.
4023 Old US 23 South
Brighton, MI. 48114
Phone: 810-494-5010
Web: <http://www.batteryrecycling.com>

RMC "Raw Material Company"
17 Invertose Dr.
Port Colborne, Ontario, Canada
Phone: 905-835-1203
Toll Free: 888-We-Reduce
Web: <http://www.rawmaterials.com/rmcmain.htm>

Profiling and waste characterization procedures must be followed prior to shipping a used lithium battery to a disposal site, so please contact the service prior to making any shipments. Please note the packaging instructions on the following pages to ensure compliance with federal transportation regulations.

For more information regarding lithium battery disposal, please contact NuFlo Measurement Systems at 1-800-654-3760.

Transportation Information

NuFlo Technologies, Inc. certifies that the lithium batteries used in the MC-II Flow Analyzer have been proven to be non-dangerous by testing in accordance with the *UN Recommendation on the Transport of Dangerous Goods, Test and Criteria*.

The regulatory references that permit the non-dangerous classification are:

USDOT 49 CFR 173.185(c)
ICAO/IATA – Special Provision “A45” (7 through 9)
IMDG Code – Page 9033a

For additional information, call NuFlo Measurement Systems at 1-800-654-3760.

Instructions for Packaging Lithium Batteries (Shipping Regulations/MOT: DOT / DOMESTIC HIGHWAY)

The quantity of lithium metal contained in any battery must not exceed 12 grams per cell and 500 grams per battery.

Battery terminals or leads must be taped to prevent short circuits.

Batteries must be packed in **INNER PACKAGINGS (bags, boxes, or foam inserts)** in a manner that will prevent movement which could cause short circuits.

Each outside package must be a **UN4G, FIBERBOARD BOX.**

Fill any remaining space with vermiculite to prevent battery movement.

Note: Packaging must meet PACKING GROUP II performance standards.

Each outside package must be marked with the name and address the **SHIPPER and CONSIGNEE.**

Each outside package must be marked:

LITHIUM BATTERIES – UN3090

Each outside package must display the following hazard label: **MISCELLANEOUS (CLASS 9)**

Emergency Response Information: 2000 ERG GUIDE NO. 138

Every shipping paper must display a 24-HOUR EMERGENCY RESPONSE TELEPHONE NUMBER.

DOT Shipping Paper Entry:

LITHIUM BATTERIES, 9, UN3090, II

Instructions for Packaging Lithium Batteries Shipping Regulations/MOT: IATA PROVISIONS USED

SHIPPER'S DECLARATION FOR DANGEROUS GOODS "NATURE AND QUANTITY OF DANGEROUS GOODS"

PROPER SHIPPING NAME	CLASS	UN NO.	PKG GRP	SUB-RISK	QTY & TYPE OF PACKAGING	PKG INST	AUTHORIZATION
LITHIUM BATTERIES	9	UN3090	II		1 FIBERBOARD BOX <u> </u> X <u> </u> KG GROSS WEIGHT	903	

Additional Information to be supplied by the SHIPPER:

1. Shipper - **FULL NAME & ADDRESS OF THE SHIPPING LOCATION**
2. Consignee – **FULL NAME & ADDRESS OF THE RECEIVING LOCATION**
3. **AIRWAY BILL NUMBER** (May be amended by Freight Forwarder)
4. Page ___ of ___ - **PAGE 1 of 1**
5. Aircraft Limitations – **PASSENGER AND CARGO AIRCRAFT (GROSS WEIGHT 5 KG OR LESS)**
CARGO AIRCRAFT ONLY (GROSS WEIGHT >5 KG to 35 KG)
6. **AIRPORT OF DEPARTURE** (May be amended by Freight Forwarder)
7. **AIRPORT OF DESTINATION** (May be amended by Freight Forwarder)
8. Shipment Type – **NON-RADIOACTIVE**
9. Shipper's Certification – **NAME/TITLE OF SIGNATORY**
PLACE AND DATE
SIGNATURE

Note: NO CORRECTIONS OR ERRORS ARE ALLOWED ON SHIPPER'S DECLARATION

The quantity of lithium metal contained in any battery must not exceed **12 grams per cell** and **500 grams per battery**.

Maximum quantity for each outside package for PASSENGER AIRCRAFT: 5 KG GROSS WEIGHT

Maximum quantity for each outside package for CARGO AIRCRAFT ONLY: 35 KG GROSS WEIGHT

Note: If gross weight exceeds 5 KG, shipment must be CARGO AIRCRAFT ONLY.

Battery terminals or leads must be taped to prevent short circuits.

Batteries must be packed in **INNER PACKAGINGS (bags, boxes, or foam inserts)** in a manner that will prevent movement which could cause short circuits.

Each outside package must be a **UN4G, FIBERBOARD BOX**.

Fill any remaining space with vermiculite to prevent battery movement.

Packaging must meet PACKING GROUP II performance standards.

Each outside package must be marked with the name and address the **SHIPPER and CONSIGNEE**.

Each outside package must be marked:

LITHIUM BATTERIES – UN3090

GROSS WEIGHT: _____ KG

Each outside package must display the following hazard label: **MISCELLANEOUS (CLASS 9)**

If gross weight exceeds 5 KG, each outside package must display a **CARGO AIRCRAFT ONLY** handling label.

Emergency Response Information: 2000 ERG GUIDE NO. 138

Every shipping paper must display a 24-HOUR EMERGENCY RESPONSE TELEPHONE NUMBER.

**Instructions for Packaging MC-II Flow Analyzers
Shipping Regulations/MOT: DOT / DOMESTIC HIGHWAY**

Equipment containing lithium batteries must be contained in strong outer packaging. The outer packaging must be waterproof or made waterproof through the use of a liner, such as a plastic bag, unless the equipment is made waterproof by nature of its construction. The equipment must be secured against movement within the outer packaging and be packed so as to prevent accidental operation during air transport.

Each outside package must be a **STRONG FIBERBOARD BOX**.

Each outside package must be marked with the name and address the **SHIPPER or CONSIGNEE**.

Each outside package must be marked:

LITHIUM BATTERIES CONTAINED IN EQUIPMENT – UN3091

Each outside package must display the following hazard label: **MISCELLANEOUS (CLASS 9)**

Emergency Response Information: 2000 ERG GUIDE NO. 138

Every shipping paper must display a 24-HOUR EMERGENCY RESPONSE TELEPHONE NUMBER.

DOT Shipping Paper Entry:

LITHIUM BATTERIES CONTAINED IN EQUIPMENT, 9, UN3091, II

Note: If packages are palletized for transportation, each **over-pack** must be marked and labeled as specified above.

Instructions for Packaging MC-II Flow Analyzers Shipping Regulations/MOT: IATA PROVISIONS USED

SHIPPER'S DECLARATION FOR DANGEROUS GOODS "NATURE AND QUANTITY OF DANGEROUS GOODS"

PROPER SHIPPING NAME	CLASS	UN NO.	PKG GRP	SUB-RISK	QTY & TYPE OF PACKAGING	PKG INST	AUTHORIZATION
LITHIUM BATTERIES CONTAINED IN EQUIPMENT	9	UN3091	II		___ FIBERBOARD BOXES X ___ KG BATTERY WEIGHT <i>(Note: 0.11 KG Battery Weight per unit)</i>	912	

Additional Information to be supplied by the SHIPPER:

1. Shipper - **FULL NAME & ADDRESS OF THE SHIPPING LOCATION**
2. Consignee – **FULL NAME & ADDRESS OF THE RECEIVING LOCATION**
3. **AIRWAY BILL NUMBER** (May be amended by Freight Forwarder)
4. Page ___ of ___ - **PAGE 1 of 1**
5. Aircraft Limitations – **PASSENGER AND CARGO AIRCRAFT**
6. **AIRPORT OF DEPARTURE** (May be amended by Freight Forwarder)
7. **AIRPORT OF DESTINATION** (May be amended by Freight Forwarder)
8. Shipment Type – **NON-RADIOACTIVE**
9. Shipper's Certification – **NAME/TITLE OF SIGNATORY**
PLACE AND DATE
SIGNATURE

Note: NO CORRECTIONS OR ERRORS ARE ALLOWED ON SHIPPER'S DECLARATION

The quantity of lithium metal contained in any piece of equipment must not exceed 12 grams per cell and 500 grams per battery.

Not more than 5 KG of lithium batteries may be contained in any piece of equipment.

Equipment containing lithium batteries must be contained in strong outer packaging. The outer packaging must be waterproof or made waterproof through the use of a liner, such as a plastic bag, unless the equipment is made waterproof by nature of its construction. The equipment must be secured against movement within the outer packaging and be packed so as to prevent accidental operation during air transport.

Each outside package must be a **STRONG FIBERBOARD BOX.**

Each outside package must be marked with the name and address the **SHIPPER and CONSIGNEE.**

Each outside package must be marked:

LITHIUM BATTERIES CONTAINED IN EQUIPMENT – UN3091
___ KG GROSS WEIGHT

Each outside package must display the following hazard label: **MISCELLANEOUS (CLASS 9)**

Emergency Response Information: 2000 ERG GUIDE NO. 138

Every shipping paper must display a 24-HOUR EMERGENCY RESPONSE TELEPHONE NUMBER.

Material Safety Data Sheet**MC-II / MC-RTU Flow Analyzers**

Revision Date: 12/3/2003

1. CHEMICAL PRODUCT AND COMPANY IDENTIFICATION**Product Trade Name:** MC-II / MC-RTU Flow Analyzers**Synonyms:** None**Chemical Family:** Blend**Application:** Battery**Manufacturer/Supplier**

NuFlo Measurement Systems

16538 Air Center Blvd.

Houston, Texas 77032

Emergency Telephone: (800) 535-5053 (InfoTrac Chemical Emergency Response Center)**2. COMPOSITION/INFORMATION ON INGREDIENTS**

<u>Substance</u>	<u>Weight Percent (%)</u>	<u>ACGIH TLV-TWA</u>	<u>OSHA PEL-TWA</u>
Thionyl chloride 7719-09-7	30 - 60%	1 ppm	1 ppm
Lithium tetrachloroaluminate 14024-11-4	5 - 10%	Not applicable	Not applicable
Lithium 7439-93-2	1 - 5%	Not applicable	Not applicable

3. HAZARDS IDENTIFICATION**Hazard Overview**

May cause eye, skin and respiratory burns. Flammable.

4. FIRST AID MEASURES**Inhalation**

If inhaled, remove to fresh air. If not breathing give artificial respiration, preferably mouth-to-mouth. If breathing is difficult give oxygen. Get medical attention.

Skin

In case of contact, immediately flush skin with plenty of soap and water for at least 15 minutes. Get medical attention. Remove contaminated clothing and launder before reuse.

Eyes

In case of contact, or suspected contact, immediately flush eyes with plenty of water for at least 15 minutes and get medical attention immediately after flushing.

Ingestion

Do not induce vomiting. Slowly dilute with 1-2 glasses of water or milk and seek medical attention. Never give anything by mouth to an unconscious person.

Notes to Physician

Not Applicable

5. FIRE FIGHTING MEASURES

Flash Point/Range (F):	Not Determined
Flash Point/Range (C):	Not Determined
Flash Point Method:	Not Determined
Autoignition Temperature (F):	Not Determined
Autoignition Temperature (C):	Not Determined
Flammability Limits in Air - Lower (%):	Not Determined
Flammability Limits in Air - Upper (%):	Not Determined

Fire Extinguishing Media

Dry lithium chloride, graphite powder, Pyrene G-1, or Lith-X. Do not use water, moist sand, carbon dioxide, halon, or soda ash extinguisher.

Special Exposure Hazards

Temperatures above 199°F (93°C) or short circuiting may cause the release of thionyl chloride. Heating above 354°F (179°C) will lead to melting of lithium and presents a severe fire and explosion hazard.

Special Protective Equipment for Fire-Fighters

Full protective clothing and approved self-contained breathing apparatus required for fire fighting personnel.

NFPA Ratings: Health 3, Flammability 1, Reactivity 1

HMS Ratings: Flammability 1, Reactivity 1, Health 3

6. ACCIDENTAL RELEASE MEASURES**Personal Precautionary Measures**

Use only competent persons for cleanup. Use appropriate protective equipment.

Environmental Precautionary Measures

Prevent from entering sewers, waterways or low areas.

Procedure for Cleaning/Absorption

Isolate spill and stop leak where safe. Contain spill with sand or other inert materials. Neutralize to pH of 6-8. Scoop up and remove.

7. HANDLING AND STORAGE**Handling Precautions**

Do not short circuit, recharge, overdischarge, puncture, crush or exposure to temperatures above 302°F (150°C). Avoid contact with eyes, skin, or clothing.

Storage Information

Store in a dry location.

8. EXPOSURE CONTROLS/PERSONAL PROTECTION**Engineering Controls**

Use in a well ventilated area.

Respiratory Protection

Acid gas respirator with a dust/mist filter.

Hand Protection

Butyl rubber gloves.

Skin Protection

Rubber apron.

Eye Protection

Chemical goggles; also wear a face shield if splashing hazard exists.

Other Precautions

Eyewash fountains and safety showers must be easily accessible.

9. PHYSICAL AND CHEMICAL PROPERTIES

Physical State:	Solid
Color:	Metallic
Odor:	Odorless
pH:	Not Determined
Specific Gravity @ 20 C (Water=1):	Not Determined
Density @ 20 C (lbs./gallon):	Not Determined
Bulk Density @ 20 C (lbs/ft³):	Not Determined
Boiling Point/Range (F):	Not Determined
Boiling Point/Range (C):	Not Determined
Freezing Point/Range (F):	Not Determined
Freezing Point/Range (C):	Not Determined
Vapor Pressure @ 20 C (mmHg):	Not Determined
Vapor Density (Air=1):	Not Determined
Percent Volatiles:	Not Determined
Evaporation Rate (Butyl Acetate=1):	Not Determined
Solubility in Water (g/100ml):	Decomposes
Solubility in Solvents (g/100ml):	Not Determined
Solubility in Sea Water (g/100ml):	Not Determined
VOCs (lbs./gallon):	Not Determined
Viscosity, Dynamic @ 20 C (centipoise):	Not Determined
Viscosity, Kinematic @ 20 C (centistokes):	Not Determined
Partition Coefficient/n-Octanol/Water:	Not Determined
Molecular Weight (g/mole):	Not Determined

10. STABILITY AND REACTIVITY

Stability Data: Stable

Hazardous Polymerization: Will Not Occur

Conditions to Avoid

Temperatures over 302°F (150°C). Moisture

Incompatibility (Materials to Avoid)

Contact with water.

Hazardous Decomposition Products

Sulfur dioxide. Hydrogen chloride.

Additional Guidelines

Not Applicable

11. TOXICOLOGICAL INFORMATION**Principle Route of Exposure**

Eye or skin contact, inhalation.

Inhalation

Causes severe respiratory irritation.

Skin Contact

Causes severe skin irritation. May cause skin burns.

Eye Contact

Causes severe eye irritation which may damage tissue. May cause eye burns.

Ingestion

Causes burns of the mouth, throat and stomach.

Aggravated Medical Conditions

Skin disorders.

Chronic Effects/Carcinogenicity

No data available to indicate product or components present at greater than 1% are chronic health hazards.

Other Information

None known.

Toxicity Tests**Oral Toxicity:** Not determined.**Dermal Toxicity:** Not determined**Inhalation Toxicity:** Not determined**Primary Irritation Effect:** Not determined**Carcinogenicity** Not determined**Genotoxicity:** Not determined**Reproductive/Developmental Toxicity:** Not determined**12. ECOLOGICAL INFORMATION****Mobility (Water/Soil/Air)** Not determined**Persistence/Degradability** Not determined**Bio-accumulation** Not determined

Ecotoxicological Information

Acute Fish Toxicity: Not determined
Acute Crustaceans Toxicity: Not determined
Acute Algae Toxicity: Not determined

Chemical Fate Information Not determined

Other Information Not applicable

13. DISPOSAL CONSIDERATIONS**Disposal Method**

Disposal should be made in accordance with federal, state and local regulations.

Contaminated Packaging

Follow all applicable national or local regulations.

14. TRANSPORT INFORMATION**Land Transportation****DOT**

Lithium Batteries Contained in Equipment, 9, UN3091, II
NAERG 138

Canadian TDG

Lithium Batteries Contained in Equipment, 9, UN3091, II

ADR

Lithium Batteries Contained in Equipment, 9, UN3091, II

Air Transportation**ICAO/IATA**

Lithium Batteries Contained in Equipment, 9, UN3091, II

Sea Transportation**IMDG**

Lithium Batteries Contained in Equipment, 9, UN3091, II

Other Shipping Information

Labels: Miscellaneous – Class 9

15. REGULATORY INFORMATION**US Regulations****US TSCA Inventory**

All components listed on inventory.

EPA SARA Title III Extremely Hazardous Substances

Not applicable

EPA SARA (311,312) Hazard Class

Acute Health Hazard
Fire Hazard

EPA SARA (313) Chemicals

This product does not contain a toxic chemical for routine annual "Toxic Chemical Release Reporting" under Section 313 (40 CFR 372).

EPA CERCLA/Superfund Reportable Spill Quantity For This Product

Not applicable.

EPA RCRA Hazardous Waste Classification

If product becomes a waste, it does NOT meet the criteria of a hazardous waste as defined by the US EPA.

California Proposition 65

All components listed do not apply to the California Proposition 65 Regulation.

MA Right-to-Know Law

Does not apply.

NJ Right-to-Know Law

Does not apply.

PA Right-to-Know Law

Does not apply.

Canadian Regulations**Canadian DSL Inventory**

Product contains one or more components not listed on inventory.

WHMIS Hazard Class

D2B Toxic Materials

16. OTHER INFORMATION**Additional Information**

For additional information on the use of this product, contact your local NuFlo representative.

For questions about the Material Safety Data Sheet for this or other NuFlo products, contact NuFlo Measurement Systems at 1-800-654-3760.

Disclaimer Statement

This information is furnished without warranty, expressed or implied, as to accuracy or completeness. The information is obtained from various sources including the manufacturer and other third party sources. The information may not be valid under all conditions nor if this material is used in combination with other materials or in any process. Final determination of suitability of any material is the sole responsibility of the user.

Material Safety Data Sheet**MC-II Lithium Battery**

Revision Date: 12/3//2003

1. CHEMICAL PRODUCT AND COMPANY IDENTIFICATION**Product Trade Name:** MC-II Lithium Battery**Synonyms:** None**Chemical Family:** Blend**Application:** Battery**Manufacturer/Supplier**

NuFlo Measurement Systems

16538 Air Center Blvd.

Houston, Texas 77032

Emergency Telephone: (800) 535-5053 (InfoTrac Chemical Emergency Response Center)**2. COMPOSITION/INFORMATION ON INGREDIENTS**

<u>Substance</u>	<u>Weight Percent (%)</u>	<u>ACGIH TLV-TWA</u>	<u>OSHA PEL-TWA</u>
Thionyl chloride 7719-09-7	30 - 60%	1 ppm	1 ppm
Lithium tetrachloroaluminate 14024-11-4	5 - 10%	Not applicable	Not applicable
Lithium 7439-93-2	1 - 5%	Not applicable	Not applicable

3. HAZARDS IDENTIFICATION**Hazard Overview**

May cause eye, skin and respiratory burns. Flammable.

4. FIRST AID MEASURES**Inhalation**

If inhaled, remove to fresh air. If not breathing give artificial respiration, preferably mouth-to-mouth. If breathing is difficult give oxygen. Get medical attention.

Skin

In case of contact, immediately flush skin with plenty of soap and water for at least 15 minutes. Get medical attention. Remove contaminated clothing and launder before reuse.

Eyes

In case of contact, or suspected contact, immediately flush eyes with plenty of water for at least 15 minutes and get medical attention immediately after flushing.

Ingestion

Do not induce vomiting. Slowly dilute with 1-2 glasses of water or milk and seek medical attention. Never give anything by mouth to an unconscious person.

Notes to Physician

Not Applicable

5. FIRE FIGHTING MEASURES

Flash Point/Range (F):	Not Determined
Flash Point/Range (C):	Not Determined
Flash Point Method:	Not Determined
Autoignition Temperature (F):	Not Determined
Autoignition Temperature (C):	Not Determined
Flammability Limits in Air - Lower (%):	Not Determined
Flammability Limits in Air - Upper (%):	Not Determined

Fire Extinguishing Media

Dry lithium chloride, graphite powder, Pyrene G-1, or Lith-X. Do not use water, moist sand, carbon dioxide, halon, or soda ash extinguisher.

Special Exposure Hazards

Temperatures above 199°F (93°C) or short circuiting may cause the release of thionyl chloride. Heating above 354°F (179°C) will lead to melting of lithium and presents a severe fire and explosion hazard.

Special Protective Equipment for Fire-Fighters

Full protective clothing and approved self-contained breathing apparatus required for fire fighting personnel.

NFPA Ratings: Health 3, Flammability 1, Reactivity 1

HMS Ratings: Flammability 1, Reactivity 1, Health 3

6. ACCIDENTAL RELEASE MEASURES**Personal Precautionary Measures**

Use only competent persons for cleanup. Use appropriate protective equipment.

Environmental Precautionary Measures

Prevent from entering sewers, waterways or low areas.

Procedure for Cleaning/Absorption

Isolate spill and stop leak where safe. Contain spill with sand or other inert materials. Neutralize to pH of 6-8. Scoop up and remove.

7. HANDLING AND STORAGE**Handling Precautions**

Do not short circuit, recharge, overdischarge, puncture, crush or exposure to temperatures above 302°F (150°C). Avoid contact with eyes, skin, or clothing.

Storage Information

Store in a dry location.

8. EXPOSURE CONTROLS/PERSONAL PROTECTION**Engineering Controls**

Use in a well ventilated area.

Respiratory Protection

Acid gas respirator with a dust/mist filter.

Hand Protection

Butyl rubber gloves.

Skin Protection

Rubber apron.

Eye Protection

Chemical goggles; also wear a face shield if splashing hazard exists.

Other Precautions

Eyewash fountains and safety showers must be easily accessible.

9. PHYSICAL AND CHEMICAL PROPERTIES

Physical State:	Solid
Color:	Metallic
Odor:	Odorless
pH:	Not Determined
Specific Gravity @ 20 C (Water=1):	Not Determined
Density @ 20 C (lbs./gallon):	Not Determined
Bulk Density @ 20 C (lbs/ft³):	Not Determined
Boiling Point/Range (F):	Not Determined
Boiling Point/Range (C):	Not Determined
Freezing Point/Range (F):	Not Determined
Freezing Point/Range (C):	Not Determined
Vapor Pressure @ 20 C (mmHg):	Not Determined
Vapor Density (Air=1):	Not Determined
Percent Volatiles:	Not Determined
Evaporation Rate (Butyl Acetate=1):	Not Determined
Solubility in Water (g/100ml):	Decomposes
Solubility in Solvents (g/100ml):	Not Determined
Solubility in Sea Water (g/100ml):	Not Determined
VOCs (lbs./gallon):	Not Determined
Viscosity, Dynamic @ 20 C (centipoise):	Not Determined
Viscosity, Kinematic @ 20 C (centistokes):	Not Determined
Partition Coefficient/n-Octanol/Water:	Not Determined
Molecular Weight (g/mole):	Not Determined

10. STABILITY AND REACTIVITY

Stability Data: Stable

Hazardous Polymerization: Will Not Occur

Conditions to Avoid

Temperatures over 302°F (150°C). Moisture

Incompatibility (Materials to Avoid)

Contact with water.

Hazardous Decomposition Products

Sulfur dioxide. Hydrogen chloride.

Additional Guidelines

Not Applicable

11. TOXICOLOGICAL INFORMATION**Principle Route of Exposure**

Eye or skin contact, inhalation.

Inhalation

Causes severe respiratory irritation.

Skin Contact

Causes severe skin irritation. May cause skin burns.

Eye Contact

Causes severe eye irritation which may damage tissue. May cause eye burns.

Ingestion

Causes burns of the mouth, throat and stomach.

Aggravated Medical Conditions

Skin disorders.

Chronic Effects/Carcinogenicity

No data available to indicate product or components present at greater than 1% are chronic health hazards.

Other Information

None known.

Toxicity Tests**Oral Toxicity:** Not determined.**Dermal Toxicity:** Not determined**Inhalation Toxicity:** Not determined**Primary Irritation Effect:** Not determined**Carcinogenicity** Not determined**Genotoxicity:** Not determined**Reproductive/Developmental Toxicity:** Not determined**12. ECOLOGICAL INFORMATION****Mobility (Water/Soil/Air)** Not determined**Persistence/Degradability** Not determined**Bio-accumulation** Not determined

Ecotoxicological Information

Acute Fish Toxicity: Not determined
Acute Crustaceans Toxicity: Not determined
Acute Algae Toxicity: Not determined

Chemical Fate Information Not determined

Other Information Not applicable

13. DISPOSAL CONSIDERATIONS**Disposal Method**

Disposal should be made in accordance with federal, state and local regulations.

Contaminated Packaging

Follow all applicable national or local regulations.

14. TRANSPORT INFORMATION**Land Transportation****DOT**

Lithium Batteries, 9, UN3090, II
NAERG 138

Canadian TDG

Lithium Batteries, 9, UN3090, II

ADR

Lithium Batteries, 9, UN3090, II

Air Transportation**ICAO/IATA**

Lithium Batteries, 9, UN3090, II

Sea Transportation**IMDG**

Lithium Batteries, 9, UN3090, II

Other Shipping Information

Labels: Miscellaneous – Class 9

15. REGULATORY INFORMATION**US Regulations****US TSCA Inventory**

All components listed on inventory.

EPA SARA Title III Extremely Hazardous Substances

Not applicable

EPA SARA (311,312) Hazard Class

Acute Health Hazard
Fire Hazard

EPA SARA (313) Chemicals

This product does not contain a toxic chemical for routine annual "Toxic Chemical Release Reporting" under Section 313 (40 CFR 372).

EPA CERCLA/Superfund Reportable Spill Quantity For This Product

Not applicable.

EPA RCRA Hazardous Waste Classification

If product becomes a waste, it does NOT meet the criteria of a hazardous waste as defined by the US EPA.

California Proposition 65

All components listed do not apply to the California Proposition 65 Regulation.

MA Right-to-Know Law

Does not apply.

NJ Right-to-Know Law

Does not apply.

PA Right-to-Know Law

Does not apply.

Canadian Regulations**Canadian DSL Inventory**

Product contains one or more components not listed on inventory.

WHMIS Hazard Class

D2B Toxic Materials

16. OTHER INFORMATION**Additional Information**

For additional information on the use of this product, contact your local NuFlo representative.

For questions about the Material Safety Data Sheet for this or other NuFlo products, contact NuFlo Measurement Systems at 1-800-654-3760.

Disclaimer Statement

This information is furnished without warranty, expressed or implied, as to accuracy or completeness. The information is obtained from various sources including the manufacturer and other third party sources. The information may not be valid under all conditions nor if this material is used in combination with other materials or in any process. Final determination of suitability of any material is the sole responsibility of the user.

WARRANTY - LIMITATION OF LIABILITY: Seller warrants only title to the products, software, supplies and materials and that, except as to software, the same are free from defects in workmanship and materials for a period of one (1) year from the date of delivery. Seller does not warranty that software is free from error or that software will run in an uninterrupted fashion. Seller provides all software "as is". THERE ARE NO WARRANTIES, EXPRESS OR IMPLIED, OF MERCHANTABILITY, FITNESS OR OTHERWISE WHICH EXTEND BEYOND THOSE STATED IN THE IMMEDIATELY PRECEDING SENTENCE. Seller's liability and Buyer's exclusive remedy in any case of action (whether in contract, tort, breach of warranty or otherwise) arising out of the sale or use of any products, software, supplies, or materials is expressly limited to the replacement of such products, software, supplies, or materials on their return to Seller or, at Seller's option, to the allowance to the customer of credit for the cost of such items. In no event shall Seller be liable for special, incidental, indirect, punitive or consequential damages. Seller does not warrant in any way products, software, supplies and materials not manufactured by Seller, and such will be sold only with the warranties that are given by the manufacturer thereof. Seller will pass only through to its purchaser of such items the warranty granted to it by the manufacturer.



NuFlo Measurement Systems
14450 John F. Kennedy Blvd.
Houston, TX 77032
Phone: 1-800-654-3760
www.nuflotech.com